

STOVAX

Fire Your Imagination

Vogue

Wood Freestanding Stove



Instructions for Use, Installation & Servicing

For use in GB & IE (Great Britain & Republic of Ireland).

IMPORTANT

THE OUTER CASING, FRONT AND GLASS PANEL BECOME EXTREMELY HOT DURING OPERATION AND WILL RESULT IN SERIOUS INJURY AND BURNS IF TOUCHED. IT IS THEREFORE RECOMMENDED THAT A FIREGUARD COMPLYING WITH BS 8423:2002 IS USED IN THE PRESENCE OF YOUNG CHILDREN, THE ELDERLY OR INFIRM.

Do not attempt to burn rubbish in this appliance.

Please read these Instructions carefully before installation or use.

Keep them in a safe place for future reference and when servicing the fire.

The commissioning sheet found on page 3 of these instructions should be completed by the Installer.



Contents

Vogue - Freestanding Stove

Covering the following models:

Vogue - VG-MID-W

Appliance Commissioning Checklist	3
User Instructions	4
Getting Started	4
User Instructions	6
Care & Maintenance.....	9
Troubleshooting	12
Installation Instructions	14
Installation Checklist.....	14
Pre-Installation Instructions	18
Installing the Appliance.....	20
Commissioning	26
Maintenance & Servicing	28
Technical Appendix	32
Spare Parts List.....	36
Service Records	39



If you have purchased your stove or fire from an authorised stockist within our Expert Retailer Network, then automatically your product will carry a 2 year warranty as standard. The 2 year warranty can be further extended to a total warranty period of 5 years by registering your Stovax Stove or Fireplace within one month of the latter of the purchase date or installation date. Accordingly, the start date for the warranty period is the date of purchase. During the registration process, the Expert Retailer details will be required for your Extended Warranty to be activated. Any product purchased outside of our Expert Retailer Network will carry a standard 12 month, non-extendable warranty.

It is a condition of the Extended Warranty that the installation complies with the relevant Building Regulations and is carried out by a suitably trained and qualified individual (HETAS in the UK or equivalent in other countries) with the certificate of installation and the Commissioning Report on Page 3 completed and retained by the end user.

Full terms and conditions are detailed in the Warranty Statement on the Stovax website www.stovax.com. In the event of any conflict of information the wording on the website shall prevail.

Important Note: Should any problems be experienced with your product, claims must first be submitted to the Expert Retailer where the appliance was purchased from who will offer immediate assistance or contact Stovax on your behalf.

DESIGN PROTECTION

The Vogue design, including accessories, is protected by Community Design Registration No. 001169338-0001 to Stovax Ltd

Appliance Commissioning Checklist

To assist us in any guarantee claim please complete the following information:-

Dealer appliance was purchased from:

Name:

Address:

Telephone number:

Essential information - MUST be completed:

Date Installed:

Model Description:

Serial Number:

Installation Engineer:

Company Name:

Address:

Telephone number:

Commissioning Checks - to be completed and signed:

Is flue system correct for the appliance:	YES <input type="checkbox"/>	NO <input type="checkbox"/>
Flue swept and soundness test complete:	YES <input type="checkbox"/>	NO <input type="checkbox"/>
Smoke test completed on installed appliance	YES <input type="checkbox"/>	NO <input type="checkbox"/>
Spillage test completed	YES <input type="checkbox"/>	NO <input type="checkbox"/>
Use of appliance and operation of controls explained	YES <input type="checkbox"/>	NO <input type="checkbox"/>
Clearance to combustible materials checked	YES <input type="checkbox"/>	NO <input type="checkbox"/>
Instruction book handed to customer	YES <input type="checkbox"/>	NO <input type="checkbox"/>
CO Alarm Fitted	YES <input type="checkbox"/>	NO <input type="checkbox"/>

Signature: Print Name:

Getting Started

Welcome

Congratulations on purchasing your Stovax Vogue, if installed correctly Stovax hope it will give you many years of warmth and pleasure for which it was designed.

The purpose of this manual is to familiarise you with your stove, and give guidelines for its installation, operation and maintenance. If, after reading, you need further information, please do not hesitate to contact your Stovax retailer.

1. General Points

- 1.1 Before installation and/or use of this appliance please read these instructions fully and carefully to ensure that you have fully understood their requirements.

The appliance must be fitted by a registered installer*, or approved by your local building control officer.

- 1.2 All local regulations, including those referring to national and European Standards need to be complied with when installing the appliance.
- 1.3 Only use for domestic heating in accordance with these operating instructions.
- 1.4 You must burn only approved fuels. Do not use with liquid fuels or as an incinerator.
- 1.5 Appliance surfaces become very hot when in use. Use a suitable fireguard[†] if young children, elderly or infirm persons are present. Stovax offer firescreens, sparkguards and hearthgate systems for protection. Your Stovax dealer can advise you about these products.
- 1.6 Do not place photographs, TV's, paintings, porcelain or other combustible items on the wall or near the appliance. Exposure to hot temperatures will cause damage. Do not place furniture or other items such as drying clothing closer than 1m from the front of this appliance.

WARNING: Extra fuel should not be stored on or next to the appliance. Only keep enough fuel for immediate use nearby and never leave the appliance unattended for long periods with any combustible material in close proximity.

- 1.7 Extractor fans or cooker hoods must not be placed in the same room or space as this can cause appliance to emit fumes into the room.
- 1.8 Do not obstruct inside or outside ventilation required for the safe use of this appliance.
- 1.9 Do not make unauthorised changes to the appliance.
- 1.10 The chimney must be swept at least once a year. See Section 13.
- 1.11 Do not connect, or share, the same flue or chimney system with another appliance.
- 1.12 This appliance is designed to be used with the door shut.

SERIAL NUMBER

- 1.13 This number is required when ordering spare parts or making warranty claims.

The data is located on the back left side of the appliance on a plate that rotates 90°, see Diagram 1.

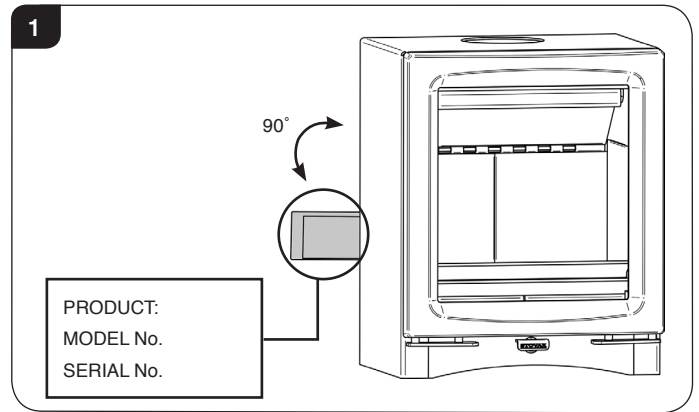

Cleanburn Technology and Convector Efficiency

This appliance incorporate the latest Cleanburn technology. Unlike conventional stoves the Vogue offers improved running, flexibility and precise combustion control via a single control to make the appliance more user friendly.

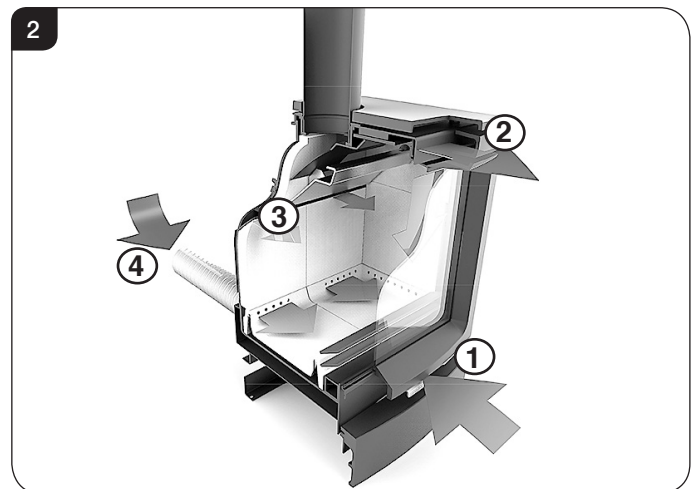

- 1) **Primary Air** - for use initially when establishing fires.
- 2) **Airwash** - air drawn over the window cleans the glass. The source of main Combustion air when burning wood.
- 3) **Cleanburn** - Secondary air is preheated through a heat exchanger to combust unburned hydrocarbons, providing a cleaner and more efficient burn.
- 4) **Outside air** (optional extra).

i **‡In the U.K. these products must conform to the latest edition of BS 8423, Fireguards for use with solid fuel appliances. If appliance is operating unattended they must conform to the latest edition of BS 3248**

***Registered on the Competent Persons Scheme (GB only see page 35/ INFO (Republic of Ireland).**

Getting Started

AIR CONTROLS

- 1.14 Use the tool provided or a protective gloved hand to operate, see Diagram 3.

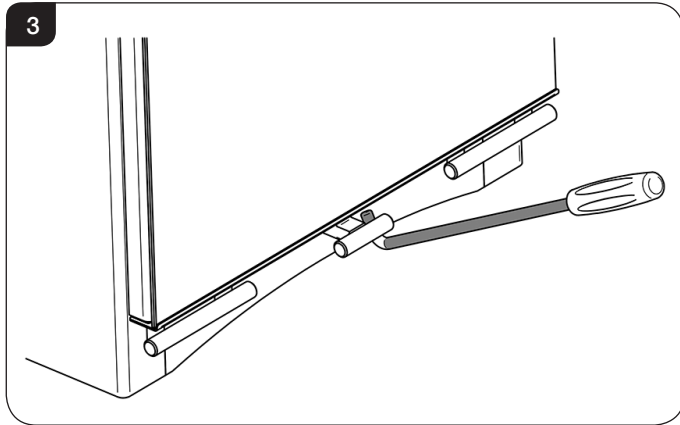

DO NOT OPERATE THE AIR CONTROLS WITH BARE HANDS

- 1.15 The air control slider is operated by pushing or pulling to increase or decrease the air flow. Each position is indicated by an indent.

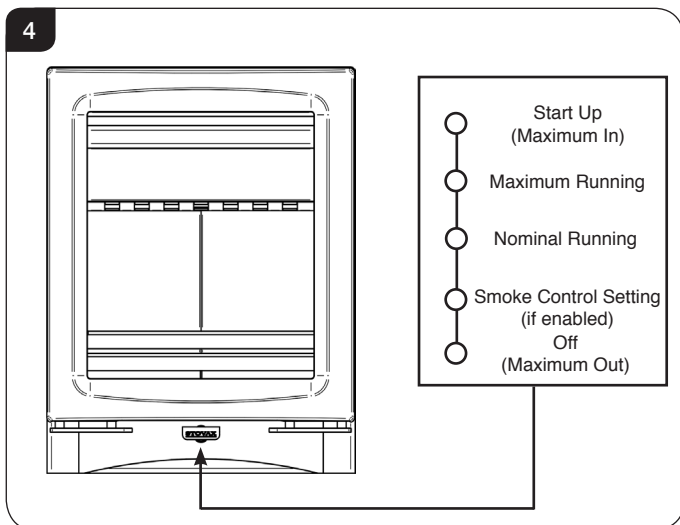

Secondary Air Control

The **Cleanburn air** enters the appliance through a hole in the rear. This is factory set to a nominal setting suitable for most chimneys. If required, this can be adjusted to suit local conditions.

Note: The Secondary Air will not close down completely. This allows a small percentage of air into the firebox to prevent an excessive build up of pressure.

DOOR HANDLE

DO NOT OPEN THE DOOR WITH BARE HANDS

DO NOT OPEN THE DOORS WHEN THE FIREBOX IS FULL OF FLAMES - WAIT FOR THEM TO DIE DOWN.

- 1.15 To open and close:

Push the right hand door handle upwards to release the catch. The door opens right to left, see Diagram 5.

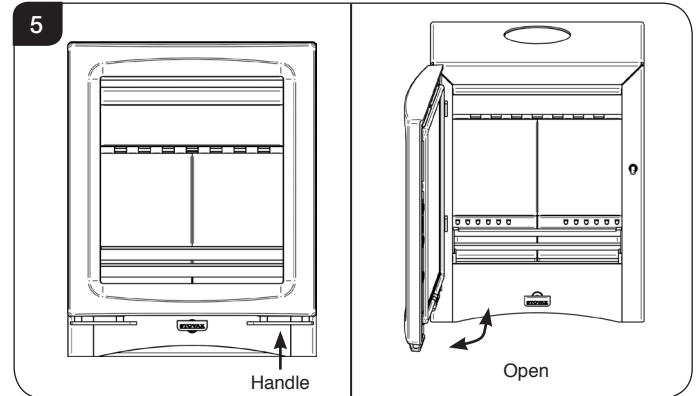

WARNING



Properly installed, operated and maintained, this appliance will not emit fumes into the room. Occasional fumes from de-ashing and refuelling may occur.

Persistent fume emission is potentially dangerous and must not be tolerated.

If fume emission does persist:

- Open doors and windows to ventilate the room.
- Leave the room.
- Allow fire to burn out and safely dispose of fuel from the appliance.
- Check for chimney blockage and clean if required.
- Do not attempt to relight until the cause of the emission has been identified and corrected
- If necessary seek expert advice.
- All open flued appliances can be affected by temporary atmospheric conditions which may allow fumes to enter the house. Because of this an electronic carbon monoxide detector conforming to the latest edition of BSEN50292 must be fitted in the same room as the appliance. The existence of an alarm must not be considered a substitute for ensuring regular servicing and maintenance of the appliance and chimney system.

IF THE ALARM SOUNDS FOLLOW THE INSTRUCTIONS GIVEN ABOVE.

Getting Started/User Instructions

2. Using the Appliance for the First Time

- 2.1 To allow the appliance to settle, and fixing glues and paint to fully cure, operate the appliance at a low temperature for first few days.
- 2.2 Do not touch the paint during the first period of use.
- 2.3 During this time the appliance may give off some unpleasant odours. Keep the room well ventilated to avoid a build-up of fumes.
- 2.4 Please be aware that, during use, rope seals may discolour. This is normal.

3. Recommended Fuels

3.1 Wood Logs:

Burn only seasoned timber with a moisture content of less than 20%. To ensure this allow cut wood to dry for 12 to 18 months.

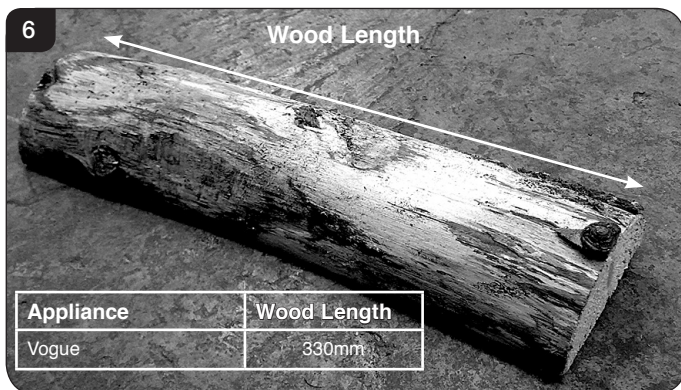

Poor quality timber:

- Causes low combustion efficiency
- Produces harmful condensation
- Reduces effectiveness of the airwash and life of the appliance

Do not burn construction timber, painted, impregnated / treated wood, manufactured board products or pallet wood.

3.2 Fuel consumption.

As tested at nominal heat output to the requirements of EN 13240: 2001 for intermittent operation:

Description	Fuel Consumption
	Kg/hour Wood
Vogue Wood	1.5

A number of factors can affect the performance of the appliance. See *Troubleshooting Section* for details.

4. Smoke Control Kit



This appliance is supplied with a pre-fitted smoke control kit and has been independently tested to PD6434 making it exempt from the controls that generally apply in Smoke Control Areas.

THE SMOKE CONTROL KIT IS SUPPLIED DISABLED AND MUST THEREFORE BE MODIFIED BEFORE INSTALLATION IN ORDER FOR THE APPLIANCE TO MEET THE REQUIREMENTS OF A SMOKE CONTROL AREA AND MUST BE OPERATED CORRECTLY TO MINIMISE THE AMOUNT OF SMOKE PRODUCED.

If this appliance is installed outside of a Smoke Control Area then the Smoke Control kit can be left disabled to give more control over the lower burn rates.

Any modifications to the kit should only be done by a suitably qualified installer and must be done at the time of installation.

- 4.1 This appliance is suitable for use in a Smoke Control Area when burning wood and following the instructions for use specified in this manual but **ONLY** if the Smoke Control kit has been enabled.
- 4.2 If the Smoke Control kit is enabled, the air control slider has restricted movement and can only be pulled out to 60mm, see Diagram 7. The air control can not be shut down completely.

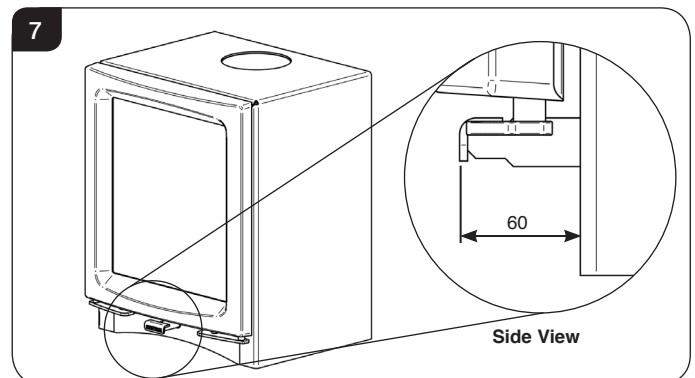

- 4.3 If the Smoke Control kit is disabled, the air control slider can be pulled out to 65mm, the maximum position, see Diagram 7. The air control can be shut down completely.

User Instructions

If the Smoke Control kit is disabled, a notch is visible when the air control is pulled out, see Diagram 8. This is not visible if the Smoke Control kit is enabled.

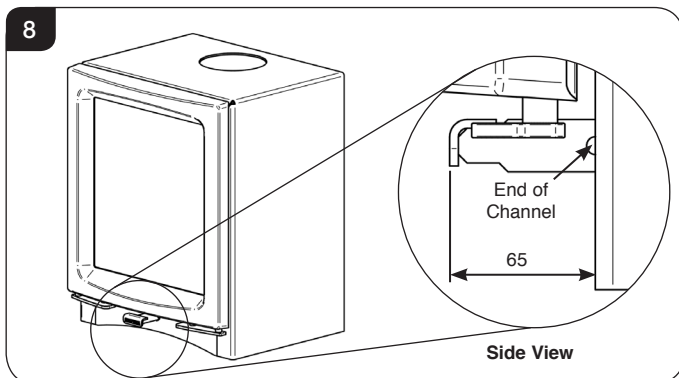

4.4 To meet the requirements of a Smoke Control Area the appliance MUST be operated correctly in order to minimise the amount of smoke produced.

i If this appliance is installed outside of a Smoke Control Area then the Smoke Control kit can be disabled to give more control over the lower burn rates. Any modifications to the kit should only be done by a suitably qualified installer and must be done at the time of installation.

These instructions must be left with the User.

5. Lighting the Appliance

5.1 For best results set air controls as shown, see Diagram 9.

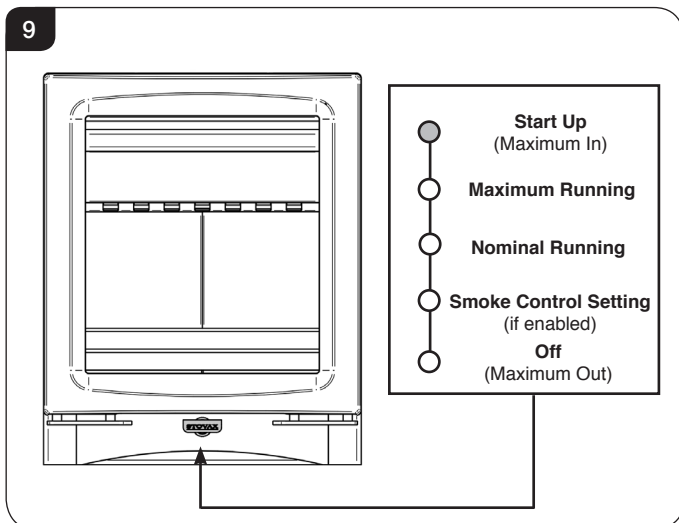

5.2 Place firelighters or paper and dry kindling wood on the base bricks.

A successful fire initially requires plenty of kindling to establish a hot firebox and warm the chimney to aid flue performance.

5.3 Light the paper or firelighters, see Diagram 10.



5.4 Leave the door slightly open as the fire establishes and the glass warms to avoid build up of condensation.

5.5 Add larger pieces of wood. Do not use full sized logs at this stage, build up gradually in size. Too many logs may smother the fire.

Do not load fuel above the log guard and the secondary combustion chamber at the back of the firebox, see Diagram 11.

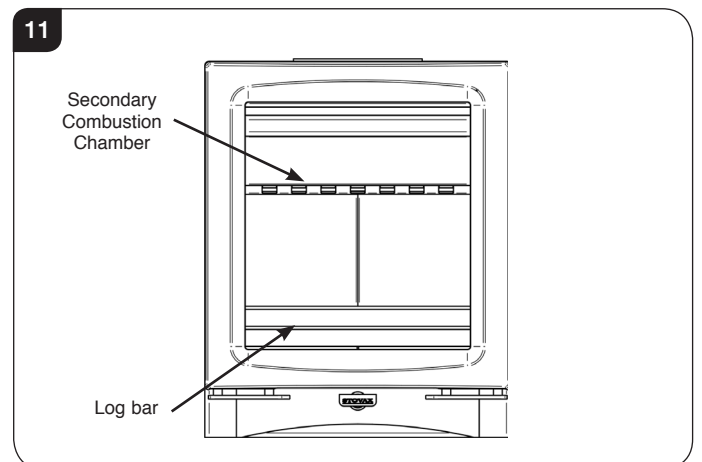

5.6 Close the door and follow the instructions for Running the Appliance.

Do not run with the door slightly open except for initial lighting as this could cause over-firing and damage the appliance.

User Instructions

6. Running the Appliance

Wood Burning

6.1 There are several settings that can be used when burning wood, see Diagram 12.

The air control slider is operated by pushing or pulling to increase or decrease the air flow. Each position is indicated by an indent.

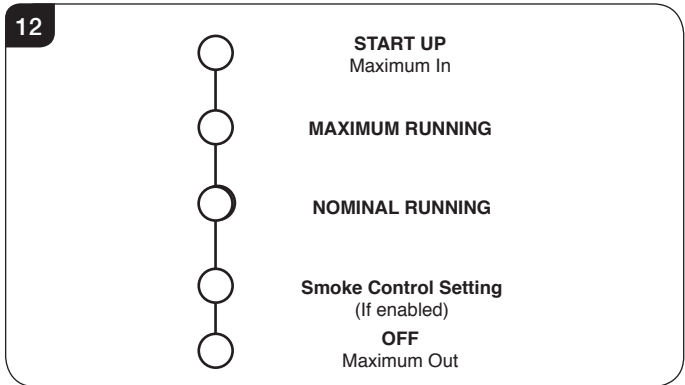

6.2 Start Up

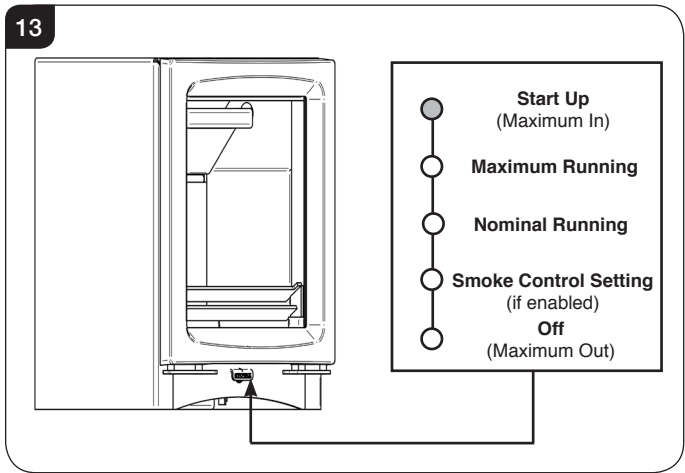

Use the Start Up setting to establish the fire and during the initial moments of refuelling. Do not run for long periods of time on this setting as this could over fire the appliance or damage the glass.

Once the fire is established:
 – Move the control lever out.
 The notched settings should be used as a guide.
 The appliance can be burnt with the control anywhere along its length.

6.3 Maximum Running

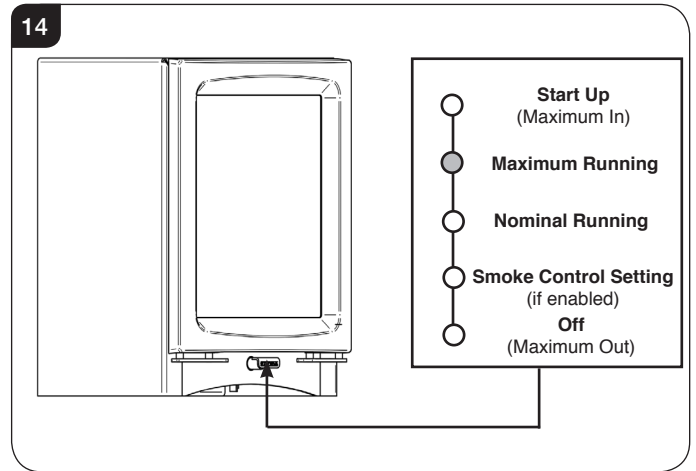

The Maximum Running setting allows the appliance to burn at the maximum output when burning wood. Take care not to over fire the appliance.

6.4 Nominal Running

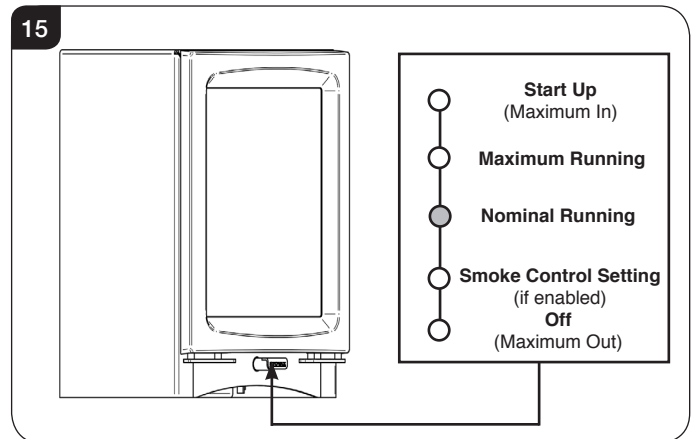

The Nominal Running setting burns wood at the most efficient output.

6.5 Smoke Control Setting - If enabled

This appliance is suitable for use in a Smoke Control Area when burning wood and following the instructions for use specified in this manual but **ONLY** if the Smoke Control kit has been enabled.

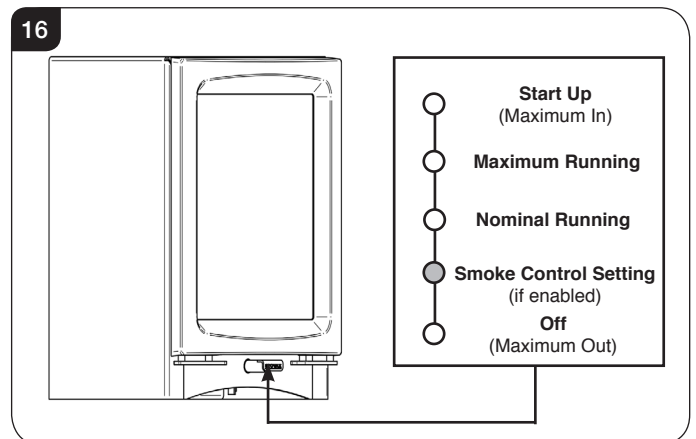

User Instructions

If the Smoke Control kit is enabled, this setting allows the appliance to burn at the lowest output. The air control can not be shut down completely.

6.6 Off/ Shut Down

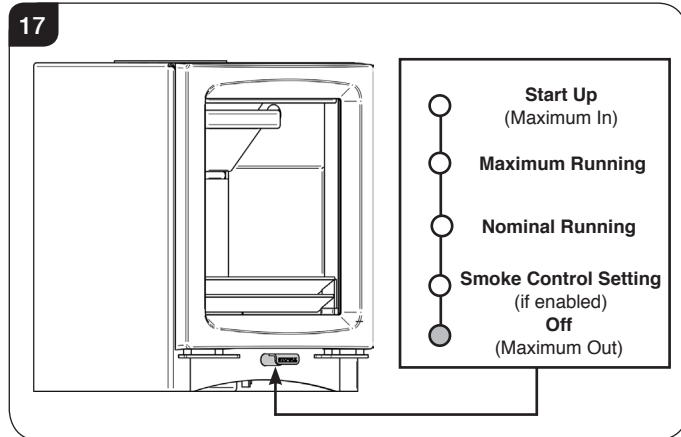

The Off/Shutdown setting for burning wood closes the fire down and turns the appliance off. This position does not keep the glass clean. This setting is not available when the Smoke Control Kit is enabled in a Smoke Control Area.

Refuelling

Wood burns best on a bed of ash (approx. 25mm (1") deep).

- 6.7 Open the air control fully to the **Start Up** setting.
- 6.8 **Do not refuel when a large amount of flames are in the firebox as this could cause smoke or flames to spill into the room.**
- 6.9 **Rake the embers evenly over the firebed to establish a glowing firebed. If the firebed is low add a small amount of kindling wood to help re-establish the fire.**

Stack the logs in an open arrangement, see Diagram 18.

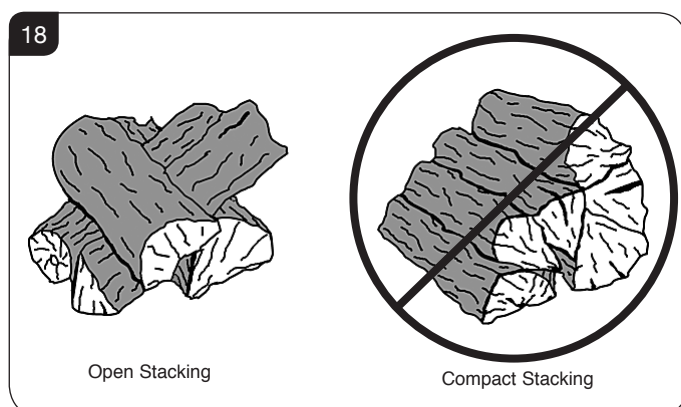

Open stacking allows oxygen to easily reach every part of the fire. Compact stacking will make the wood burn slower as fire can only reach the outside of the wood. This will cause the fire to smoulder and produce smoke.

- 6.10 **Close the door immediately after refuelling.**
- 6.11 After refuelling:
Burn the new logs at a high temperature for a few minutes before adjusting the air control.

Do not close the air control until the fire is burning well.
- 6.12 Experience establishes settings to suit personal preferences.
- 6.13 **Do not burn large amounts of fuel with the air control closed (Off position) for long periods of time. This reduces the glass cleaning effect, causes tars and creosotes to build-up in the appliance and flue system and will produce excessive amounts of smoke.**
- 6.14 When in use, running the appliance at a high temperature for a short period also reduces tars and creosote.
- 6.15 When running the appliance **refuel little and often for clean, efficient burning.**

A bright and clean firebox indicates the appliance is burning well.
- 6.16 **Do not load fuel above the log guard and the Secondary Combustion Inlets at the back of the firebox, see Diagram 10.**

Fuel Overloading

The maximum amount of fuel specified in this manual should not be exceeded, overloading can cause excess smoke.

- 6.17 **Do not burn continuously with the door open.**

WARNING: DO NOT OPERATE THE APPLIANCE WITH THE AIR CONTROL ON START UP FOR LONG PERIODS OF TIME AS THIS COULD CAUSE OVER-FIRING AND MAY CAUSE PERMANENT DAMAGE.

Burning Tips

- 6.18 **Fuel Quality (Wood)**

Use wood with a moisture content of less than 20%. Seasoned logs have the bark beginning to lift and peel away and cracks radiating from the centre. They feel lighter than fresh cut wood of a similar size and sound hollow when struck against each other. Logs should not feel damp or have moss and fungal growths.

Symptoms related to wet wood:

- Difficulty starting and keeping a fire burning well.
- Smoke and small flames.
- Dirty glass and/or firebricks.
- Rapid creosote build-up in the chimney.
- Low heat output.
- Short burn times, excessive fuel consumption and blue/grey smoke from the chimney.

Run at a high temperature for a short period each day to avoid large build-ups of tars and creosote within the appliance and the flue system. Use Stovax Protector chimney cleaner to reduce this problem.

Care & Maintenance

Shut Down

- 6.19 If there is still burning fuel in the firebox, Stovax do not recommend shutting down the air controls completely unless there is a chimney fire in progress (see Section 10 for advice). Closing the control during the burning process will cause poor combustion and could lead to a build up of gasses that could ignite dangerously.
- 6.20 Always have enough air entering the stove to maintain some flame within the firebox.
- 6.21 If it is necessary to shut down the appliance then run on a high setting until all of the fuel has been burnt before closing the air controls.

7. Extended Burning

- 7.1 It is possible to get the appliance to burn for extended periods of time. In order to do this:
- De-ash prior to final refuelling.
 - Burn new fuel at a high temperature for a few minutes before adjusting the **Control**.
 - Set air controls to low combustion settings.
This will gradually blacken the glass but it will clear when operated at a high temperature for a short period.

8. Ash Removal

Do not allow ash to build up as it may cause damage and adversely effect the performance of the appliance. Warning: Ash can remain hot long after appliance has been in use.

- 8.1 **Wood**
- Open Doors.
 - Leave a layer of ash to start the new fire on. Wood burns best on a bed of ash (approx. 25mm (1") deep).
 - Remove ash with a small shovel and place into an Ash Caddy (Part No. 4227) or other suitable container.

Do not place hot ash in any container made from plastic or any other combustible material.

- De-ash at least once a week.

9. Over-Firing

- 9.1 Do not over-fill with fuel or run at high temperatures for long periods or over-firing can occur.
WARNING: DO NOT OPERATE THE APPLIANCE WITH THE AIR CONTROL FULLY OPEN FOR LONG PERIODS OF TIME AS THIS COULD CAUSE OVER-FIRING AND MAY CAUSE PERMANENT DAMAGE.
- 9.2 **Over-firing can cause permanent damage to the appliance and invalidate the product warranty.**

10. Chimney Fire

- 10.1 **If a chimney fire occurs:**
- **Shut all air controls immediately.**
 - **Evacuate the building.**
 - **Call the fire brigade.**
 - **Do not re-enter the building until it is confirmed safe.**
- 10.2 **Do not use the appliance after a chimney fire until:**
- a) **It has been inspected by a registered installer*, confirming the appliance is safe to use.**
- b) The chimney system has been inspected and swept by a chimney sweep, confirming the system is structurally sound and free from obstruction*.
- c) **It is repaired as required before re-use.** Use only genuine Stovax replacement parts to keep your appliance in safe, efficient working order.

11. General Cleaning

- 11.1 Clean and inspect the appliance regularly, especially in periods of heavy use. Regular cleaning and maintenance will help give many years of safe use.
- 11.2 **Allow appliance to cool thoroughly to avoid risk of burns.**
- 11.3 Clean regularly, according to level of use.
- Remove the ash completely
(see *User Instructions, Section 8*).
- 11.4 Check internal components for damage and for obvious build up of soot, ash or debris above the flue baffle(s) (these can be found in the upper part of the firebox). Use a torch if necessary.
- 11.5 If there are any signs of a build up of debris above the flue baffle(s) either:
- Arrange for the chimney to be swept (see *User Instructions, Section 13*).
 - Remove the baffles and clear the debris
(see *Pre-Installation Instructions, Section 3*).
- 11.6 To refresh painted finishes a touch up spray is available. Contact your Stovax retailer quoting the serial number found on the appliance data badge.
- Do not use aerosol sprays near an operating appliance. Do not use abrasive cleaner or cleaning pads.**
- 11.7 Check that the door shuts properly and creates an effective seal. Leaking door seals prevent the appliance working properly.



*Registered on the Competent Persons Scheme (GB only) see page 35/ INFO (Republic of Ireland).

Care & Maintenance

12. Cleaning Glass

- 12.1 Keep the glass clean with correct use of the Airwash system and good quality fuel. Use the boost setting to clear any build up.
- 12.2 Sometimes additional cleaning may be required. Before undertaking this operation allow appliance to cool fully. Do not clean hot glass.
- 12.3 **On appliances with printed glass do not use cleaning agents that have a high alkaline or acidic content, for example Stovax Gel Cleaner, these are aggressive cleaning agents designed to be used with heavily stained clear glass. On printed glass surfaces, use Stovax Glass Cleaner (Stovax No.4103) which is better formulated for this application.**
- 12.4 Before applying a cleaning agent remove any dust and loose soot with a damp cloth.
- 12.5 Use an appropriate glass cleaner. Apply the cleaning fluid to a cloth before rubbing onto the glass. Apply carefully and do not apply excessively. Do not apply directly onto the glass. Try to prevent any run off which could soak into the rope seals around the edge of the glass. Soot can also contain acidic particles that can cause corrosive damage to printed glass.
- 12.6 Remove dirt with a moist cloth and buff dry.
- 12.7 **Some types of wood and solid fuel can cause a white residue to form on the glass. If this occurs it should be cleaned off at least once a week during periods of heavy usage. If the liquid cleaning agents recommended do not remove this residue use a dry cleaning pad which will help remove these white marks.**
- 12.8 Before relighting the appliance ensure the glass is fully dried. If the rope seal has absorbed excess cleaning agent it is advisable to replace the rope as soon as possible to preserve the printed finish of the glass.

13. Chimney Sweeping

- 13.1 To maintain safe and efficient use of the appliance, the chimney/flue must be inspected and swept at least once a year by a qualified chimney sweep*.

If the appliance is used continuously throughout the year, or it is used to burn wood, more frequent sweeping is recommended.

The best time to have the chimney swept is at the start of the heating season.
- 13.2 The chimney, any connecting flue pipe and the appliance flue ways, if incorporated, must be regularly cleaned.
- 13.3 Ensure adequate access for cleaning where it is not possible to sweep through the chimney.
- 13.4 If the chimney is believed to have previously served an open fire it must be swept a second time within a month of regular use after installation.

14. Care Of Stove

Stovax has a range of cleaning and maintenance products and accessories to keep your appliance in good working order. Your Stovax retailer can advise you on suitable items for your stove and provide genuine spare parts such as replacement glass, door sealing rope and firebricks. View the extensive range at www.stovax.com by clicking on *Accessories*. In addition, an annual service by a competent engineer is recommended to keep your stove in the best possible condition.

15. Seasonal Use

- 15.1 Clean and service the appliance if not used during the warmer months, as detailed in the *Maintenance and Servicing* section.
- 15.2 Set the air controls to 50% to keep the appliance ventilated and stop the build-up of any moisture inside.
- 15.3 Before re-lighting the appliance:
 - Remove the baffles.
 - Clear any debris that may have accumulated.
 - Check the flue is clear of any blockages.

16. Replacing Door Glass

- 16.1 To maintain the safe use of your appliance you may need to replace a damaged door glass.
- 16.2 Using the appliance with a damaged door glass could cause dangerous fumes to enter the room, or the appliance to over-fire, resulting in damage.
- 16.3 A new door glass and installation instructions (PM484) are available from your retailer.

17. Optional Extras

Outside Air Kit

- 17.1 This appliance can be fitted with an optional kit to help bring air directly into the appliance from outside. For installation and operating procedures refer to the instructions supplied with the Outside Air kit - Stovax Part No PM373.

Heat Shield

- 17.2 This appliance can be fitted with a heat shield in order to decrease the distance the appliance can be installed from a wall. This must be done at the time of installation. Please refer to instructions.

Appliance	Part No.
Vogue	RVN-MIDHSK

Troubleshooting

Troubleshooting

	Symptom	Cause	Solution
OPERATION	Difficulty starting the fire and keeping it burning well	Low flue draught	Consult your installer
		Wet wood (over 20% moisture)	Use dry seasoned wood (less than 20% moisture content)
	Poor burning control	High flue draught	Consult your installer
	Short burn times	Wet wood (over 20% moisture) Insufficient amount of fuel - Refer to the table in section 3	Use dry seasoned wood (less than 20% moisture content)
	Excessive heat output (Over firing)	High flue draught	Consult your installer
		Air control left fully open	Close air control to reduce output
	Low heat output	Low flue draught	Consult your installer for advice on suitable flue system
		Wet wood (over 20% moisture)	Use dry seasoned wood (less than 20% moisture content)
Excessive fuel consumption	High flue draught	Consult your installer for advice on suitable flue system	
	Over dry wood	Do not use constructional timber or pallet wood	
SMOKE EMISSIONS	Smoke and small flames	Wet wood (over 20% moisture)	Use dry seasoned wood (less than 20% moisture content)
	Intermittent smoke spillage into room when appliance door is opened	Low flue draught	Consult your installer for advice on suitable flue system
		Incorrect additional ventilation air in to building	Consult your installer
	Continuous smoke spillage into room when appliance in use	Blocked flue	Open all doors and windows to ventilate the room. Allow the fire to burn out. Check flue for blockage. Do not re-use until cause of spillage is identified. Consult your installer for advice
Blue/grey smoke from chimney	Wet wood (over 20% moisture)	Use dry seasoned wood (less than 20% moisture content)	
ADVERSE WEATHER	Windy days, intermittent smoke spillage into room when appliance door is opened	Down draught in flue caused by air turbulence caused by nearby buildings or trees	Weather conditions combined with the flue terminal position can have an effect on the appliance performance. Consult your installer
	Calm days, intermittent smoke spillage into room when appliance door is opened	Over size flue giving poor flue draught	Weather conditions combined with the flue terminal position can have an effect on the appliance performance. Consult your installer
	Damp/Rainy days lighting and burning problems	Flue temperature low / rain water inside flue	Use good quality wood to start and maintain the fire, consult your installer to fit a rain cowl
	Wind noise from the air control	High flue draught	Consult your installer for advice on suitable flue system

Troubleshooting

	Symptom	Cause	Solution
THE APPLIANCE	Rapid creosote build-up in the chimney	Wet wood (over 20% moisture)	Use dry seasoned wood (less than 20% moisture content). Operate at a high temperature for short periods each time the appliance is used to avoid large build-ups of tars and creosotes
	Tar coming from flue joints	Appliance operated at continuous low temperatures	Operate at a high temperature for short periods each time the appliance is used to avoid large build-ups of tars and creosotes. See user instructions for correct use of air control
		Using poor quality wood	Use dry seasoned wood (less than 20% moisture content)
	Strong pungent smell after the appliance is lit	Appliance operated at continuous low output	Operate at high output for short periods. See user instructions for correct use of air control
		Using poor quality wood	Use dry seasoned wood (less than 20% moisture content)
	Wind noise from the air control	High flue draught	Consult your installer for advice on suitable flue system
	Dirty firebricks	Wet wood (over 20% moisture)	Use dry seasoned wood (less than 20% moisture content)
	Dirty glass	Wet wood (over 20% moisture)	Use dry seasoned wood (less than 20% moisture content)
	Glass blackening	Using poor quality wood	Use dry seasoned wood (less than 20% moisture content)
		Low flue draught	Consult your installer for advice on suitable flue system
Incorrect use of air control		See user instructions for correct use of air control	
Appliance operated at continuous low temperatures		Operate at high output for short periods. See user instructions for correct use of air control	

FLUES	The flue system has two main functions:
	<ul style="list-style-type: none"> - To safely remove the smoke, fumes and combustion gases from the building. - To provide a sufficient amount of flue draught (suction) in the appliance to ensure the fire keeps burning.
	The flue draught is caused by rising hot gases when the appliance is lit.
	Tar and creosote are a major cause of chimney fires. If the appliance experiences problems with tar build up consult a chimney sweep before continued use of the appliance.
	For advice on the correction of persistent flue problems consult a qualified heating engineer before continuing to use the appliance.

Installation Checklist

Please Note

This section is intended to give an overview of the product performance and essential information required for installing the appliance. It is intended for qualified engineers who are already familiar with Stovax products.

For full details and expanded information please see the Technical Appendix at the back of this manual.

1. Vogue Dimensions

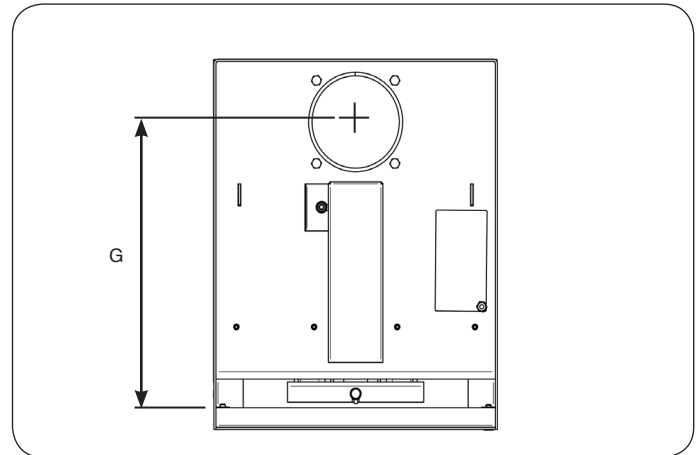
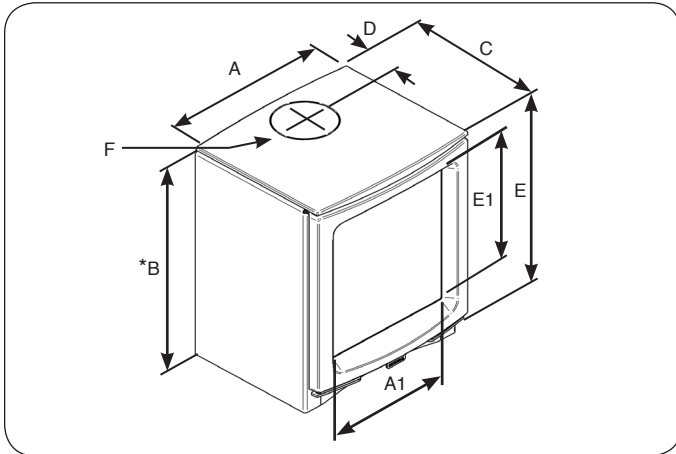

STANDARD CAST PLINTH

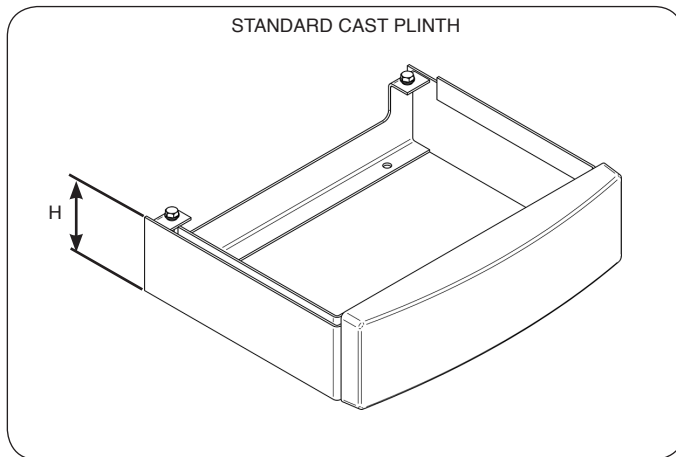

MIDLINE/ WOODSTORE CAST PLINTH

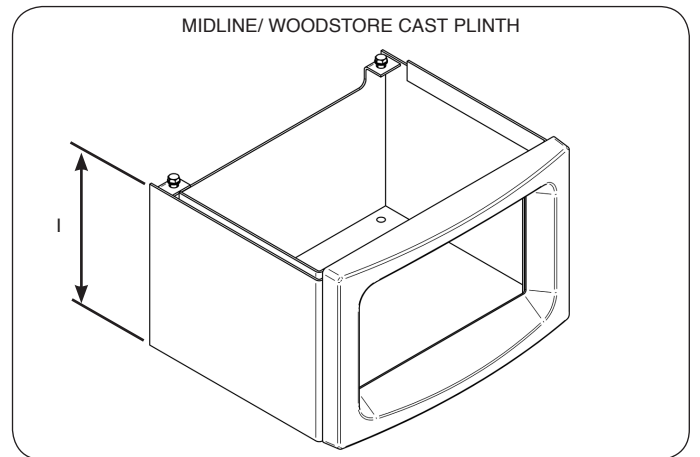

Description	A	A1 Glass Viewing Area	B	C	D	E	E1 Glass Viewing Area	F (dia)	G	H Standard plinth only	I Midline plinth only
Vogue	416	306	*537	372	109	459	337	128	426	100	249

All dimensions in mm (25.4 mm = 1")

*To top of cast plate

Installation Checklist

2. Essential Information

GENERAL	Model:			
	Vogue			Vogue
	Nominal Heat Output	Wood	kW	5.0
	Efficiency	Wood	%	81
	CO @ 13% O ₂	Wood	%	0.13
Weight	Wood	Kg	70	
Recommended Fuels	Wood	Seasoned Wood (less than 20% moisture content)		

As tested to the requirements of EN 13240 for intermittent operation

FLUES	Flue/Chimney Size ‡May be reduced to 128mm (5") if burning approved smokeless fuels or burning wood in an appliance approved for use in a DEFRA smoke control area	Without flue liner Round (Diameter)	mm	‡153
			inch	‡6
		Without flue liner system (Square)	mm	135
			inch	5 1/2
		With Liner of Factory made system (diameter) installed in accordance with manufacturers instructions	mm	150
			inch	6
	Flue/Chimney minimum height**	All products **must be 4.5m from the hearth to the top of the flue, with no horizontal sections and a maximum of 4 bends. Bends must have angles of less than 45 degrees from the vertical.	m	4.5
			feet	13
	Flue Draught	Min	mm Wg	1.0
		Nominal		1.5
Max		2.0		
Flue Gas Mass Flow	Wood	g/s	7.1	
Flue Gas Temperature at Spigot/Socket	Wood	°C	269	
Flue Outlet Size (Top or Rear Option)	All	mm	128	
		inch	5	

European Min Spec for Chimney Flue - T400 N2 D 3 G50

VENTILATION	A) Traditionally Built Homes		B) Modern Construction Homes	
	• Where leakage is greater than 5m ³ /hour/m ² .		• Where leakage is less than 5m ³ /hour/m ² .	
	• Ventilation normally required = 550mm ² per kW output over 5kW		• Ventilation normally required = 550mm ² per kW	
	A	Additional Ventilation	mm ²	None
			cm ²	None
			in ²	None
B	Additional Ventilation	mm ²	2750	
		cm ²	27.5	
		in ²	4.4	

For full technical details on ventilation see Technical Appendix on Page 34

i In the U.K. Additional information covering the installation of the appliance may be found in the following British Standards: BS EN 15287, BS6999, BS8303.

Installation Checklist

3. Minimum Dimensions - Hearth

3.1 Hearth construction must comply with the building regulations in force[†]. The appliance must stand on a non-combustible constructional hearth which is at least 125mm thick with the minimum dimensions as shown in Diagram 1.

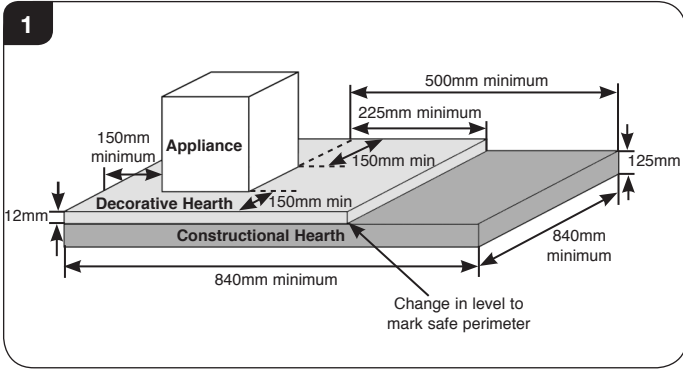

3.2 If this appliance is installed in an elevated setting it is recommended to increase the 225mm hearth depth to safely contain any falling logs or embers. The higher the appliance is installed the deeper the hearth should be to avoid scorched floor coverings.

4. Clearances

IMPORTANT: INSTALLATION MUST COMPLY WITH CURRENT BUILDING REGULATIONS.

ENSURE THAT SUFFICIENT CLEARANCES ARE PROVIDED BETWEEN THE FLUE PIPE AND ANY COMBUSTIBLE MATERIALS IN THE FIREPLACE IN ACCORDANCE WITH THE RULES IN FORCE.[†]

4.1 When installing a Vogue stove it is important to observe the following clearances to both **combustible** and **non-combustible** materials. Also ensure that a clearance of 1 meter is maintained in front of the appliance when operating.

Fireplace: Minimum Clearances Above & to the Sides

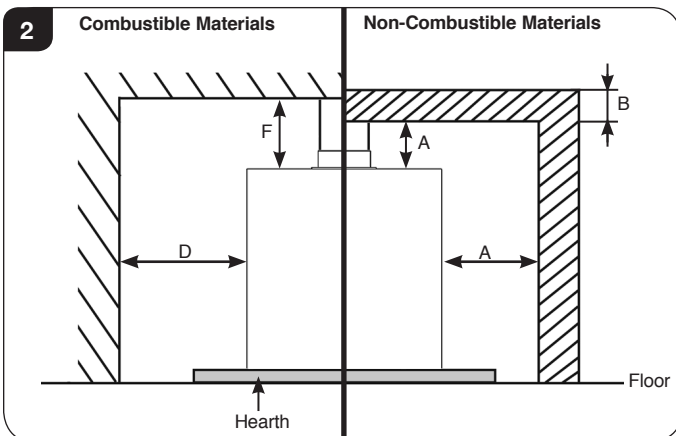

Fireplace: Minimum Clearances to the Rear

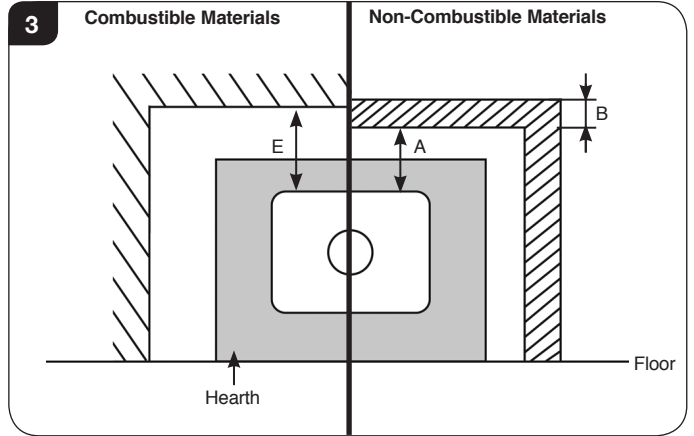

Non-Combustible Materials

4.2 All appliances will require some clearance between them and any non-combustible materials to allow for either:

- Installation, servicing or accessing controls.
- Convection in order for the appliance to function properly.

Recommended: Minimum clearances for installation/servicing/convection is:

Rear - 25mm	Sides - 50mm	Top - 100mm
-------------	--------------	-------------

NOTE: If the non-combustible surface is less than 200mm thick additional clearances may be required. This requirement ensures that the non-combustible material does not transmit excessive heat through the wall onto combustible material which might be placed against it.

See Diagrams 2 & 3 (Fireplaces) & Diagram 4 (Freestanding) and table below.

Distance to Non-combustible Materials		
Distance of Appliance to Wall (A)	Minimum Thickness of wall (B)	Minimum Height of Wall (C)
0mm - 50mm*	200mm	Height of appliance + 300mm OR 1200mm from the hearth (take largest dimension)
51mm - 300mm	75mm	
300mm+	No requirement	No requirement

i † England and Wales – Document J / Scotland - Part F/Document J (Republic of Ireland only)

Installation Checklist

Freestanding Installation

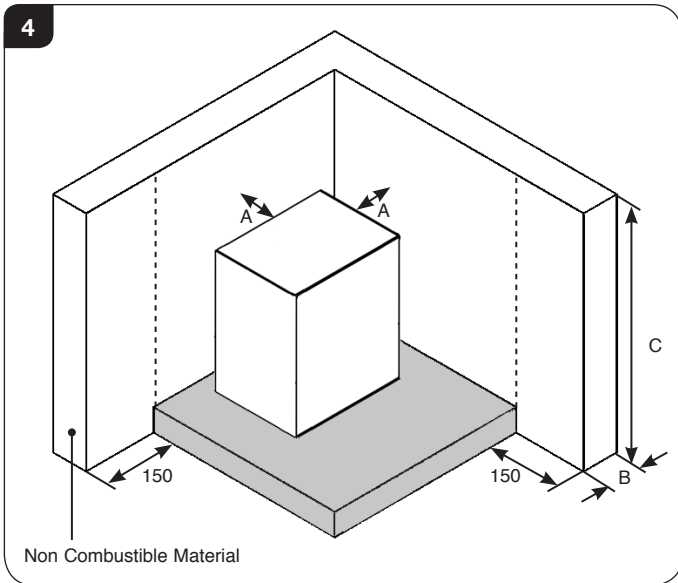

Combustible Materials

4.3 It is essential for safety to ensure the following clearances to combustible materials are maintained.

See Diagrams 3 & 4 and table below.

Model	D (side)	E (Rear)*	F (Above)
Vogue	550	700	N/A

* Note this distance can be reduced by the fitting of a heat shield kit, check with your Stovax retailer for availability and clearances.

5. Optional Extras

Outside Air Kit

5.1 This appliance can be fitted with an optional kit to help bring air directly into the appliance from outside. For installation and operating procedures refer to the instructions supplied with the Outside Air kit - Stovax Part No PM373.

Heat Shield

5.2 This appliance can be fitted with a heat shield in order to decrease the distance the appliance can be installed from a wall. This must be done at the time of installation. Please refer to instructions.

Appliance	Part No.
Vogue	RVN-MIDHSK

Pre-Installation Instructions

1. General

- 1.1 To make the installation of the appliance easier it is best to remove the internal components before fitting into the builders opening/studwork.

PACKING LIST

- User & Installer Instructions
- Warranty card
- Pair leather gloves
- Operating Tool
- Thermic Seal

STANDARD FEATURES

- Primary air
 - Airwash (for wood burning / clean glass).
 - Factory set Secondary air (to ensure complete burning of flue gases)
 - Top or rear flue exit option
- 1.2 For the best results removing the following components as set out below.

2. Removal of the Log Guard

- 2.1 To remove the Log guard:
- Lift Log Guard clear of the supporting brackets.
 - Rotate to clear the sides of the door opening.

Do not use appliance without the log guard in position.

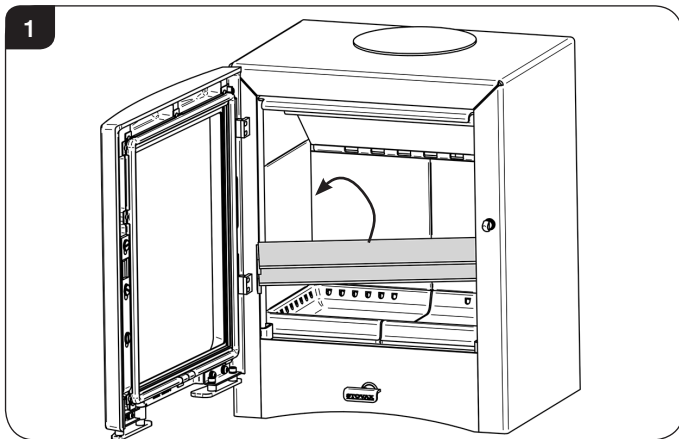

3. Removal of the Baffles

No tools are required.

- 3.1 To maintain efficient combustion the appliance is fitted with a twin baffle system, consisting of an upper and lower baffle.
- 3.2 First remove the Log Guard from the appliance to give access to the firebox.

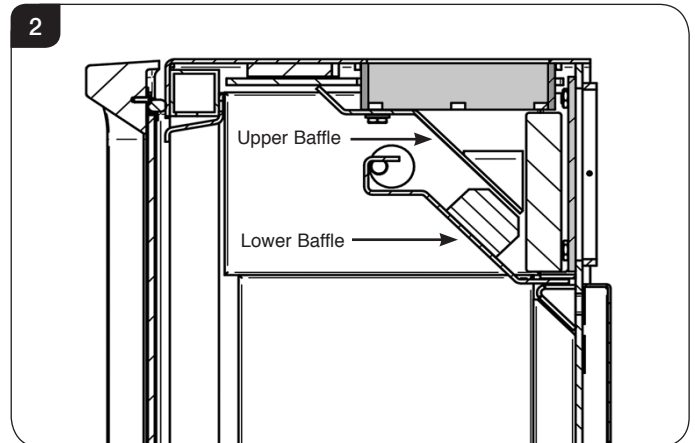

- 3.3 Remove the **Lower Baffle**, see Diagram 3, by lifting the front edge slots from the support bars on the appliance sides.

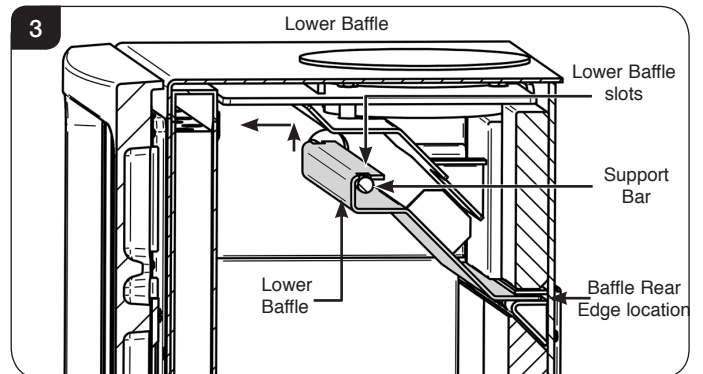

- Pull the baffle forward to disengage the rear edge from the location above the secondary air holes.
- Rotate the baffle to remove from the firebox through the door opening.

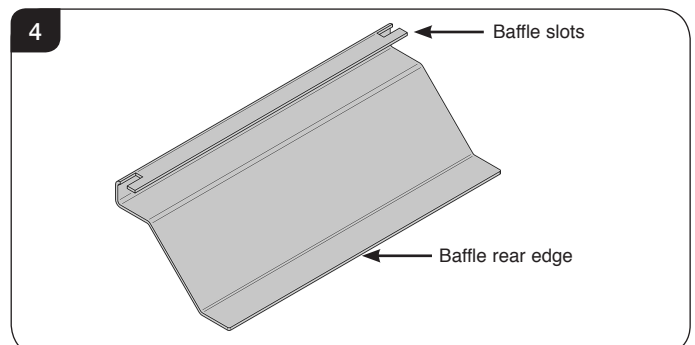

Pre-Installation Instructions

3.4 Remove the **Upper Baffle**, see Diagram 5 & 6, by pulling it forward to disengage from the hanging points at the top of the firebox. This enables it to drop down.

- Lift the baffle over the top of the support pins and rotate through the door opening.

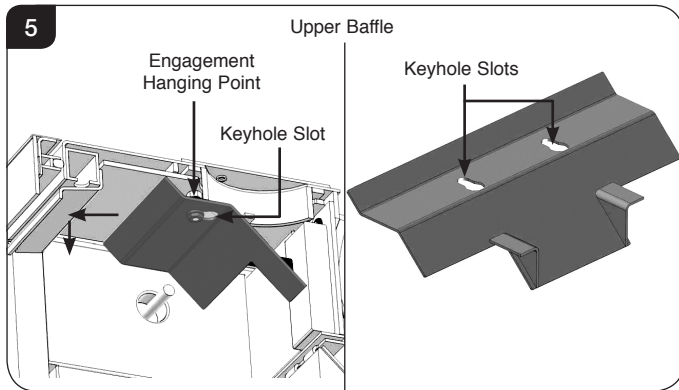

3.6 Reverse the above process to replace the baffles.

Do not modify the baffle.

4. Removal of the Fire Bricks

- 4.1 Remove the firebricks as part of the routine maintenance. This can be carried out without the use of tools.
- 4.2 Allow the appliance to cool fully before removing firebricks.
- 4.3 Take care when handling, as bricks can become fragile after use. Life span depends on the type of fuels burnt and the level of use.
- Replace damaged bricks as soon as possible.
- 4.4 Remove the log guard and baffles (see Section 2 & 3).
- Remove the bricks in the correct order as shown in Diagram 6.

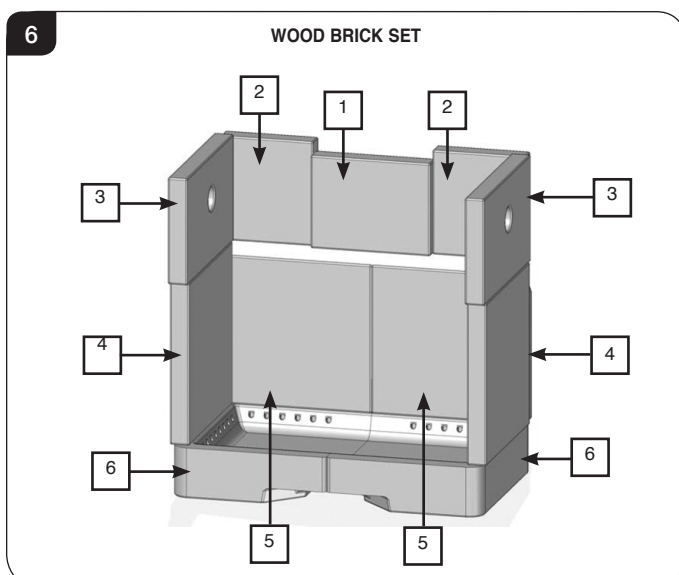

4.5 Re-install in reverse order.
Note: Brick 1 is not fitted if the appliance is configured for Rear Flue option.

Installation Instructions

1. Installing the Appliance

Each installation is unique to the property so it is not possible to give details to suit every setting. The installation must comply with Building Regulations† and be made using "best practice" construction methods‡.

Many fireplace openings have a supporting lintel. Do not remove without supporting the remaining structure of the building. **Do not support the structure with the appliance or the flue system.**

- 1.1 **Take care when installing the appliance. Careless handling and use of tools can damage the finish and/or area.**
- 1.2 If the appliance is to be installed with an optional decorative plinth, it needs to be fitted prior to installation, see Section 4.



Smoke Control Kit

This appliance is supplied with a pre-fitted smoke control kit and has been independently tested to PD6434 making it exempt from the controls that generally apply in Smoke Control Areas.

THE SMOKE CONTROL KIT IS SUPPLIED DISABLED AND MUST THEREFORE BE MODIFIED BEFORE INSTALLATION IN ORDER FOR THE APPLIANCE TO MEET THE REQUIREMENTS OF A SMOKE CONTROL AREA AND MUST BE OPERATED CORRECTLY TO MINIMISE THE AMOUNT OF SMOKE PRODUCED.

This appliance is suitable for use in a Smoke Control Area when burning wood and following the instructions for use specified in this manual but **ONLY** if the Smoke Control kit has been enabled.

If this appliance is installed outside of a Smoke Control Area then the Smoke Control kit can be disabled to give more control over the lower burn rates.

Any modifications to the kit should only be done by a suitably qualified installer and MUST be done at the time of installation, see Installation Section 6.

- 1.3 Select and fit the required flue option.
- 1.4 If the appliance is to be fixed to the hearth then use the mounting bracket shown, see Diagram 1.
- 1.5 Position the appliance where required on the hearth and mark the location of the fixing holes in the mounting bracket.
- 1.6 Drill the required sized holes into the hearth.



† England and Wales – Document J / Scotland - Part F/Document J (Republic of Ireland only)
‡ the latest edition of BS 8303, BS EN 15287, BS 7566

- 1.7 Use suitable fasteners to fix in place.

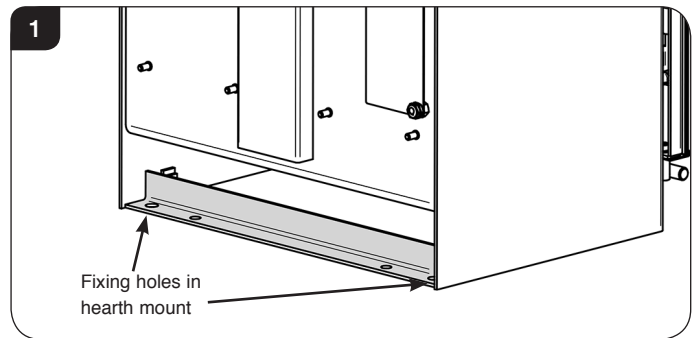

2. Top Flue Installation

- 2.1 The appliance is factory supplied with a top flue outlet but the flue collar and blanking plate require sealing with Fire Cement before use, see Diagram 2.

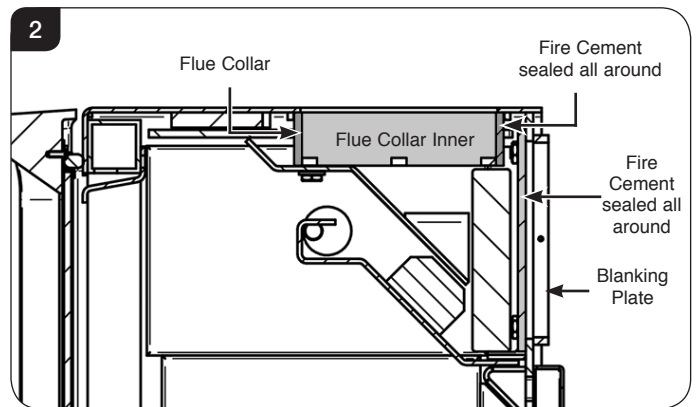

- 2.2 To fit the pipe to the collar:
 - Lift appliance into position.
 - Take care not to damage the hearth finish.

Cast Top Plate

The cast top plate must be fitted prior to connecting the flue.

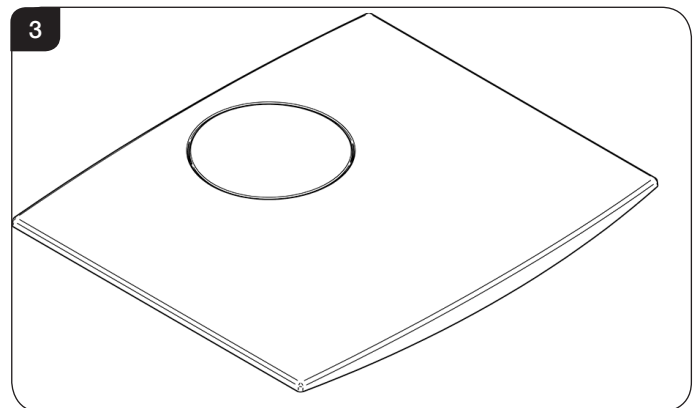

Installation Instructions

2.3 Line up the cast top flush with the front and sides of the appliance.

2.4 For the top flue version position the hole cutout concentrically with the flue and flue ring.

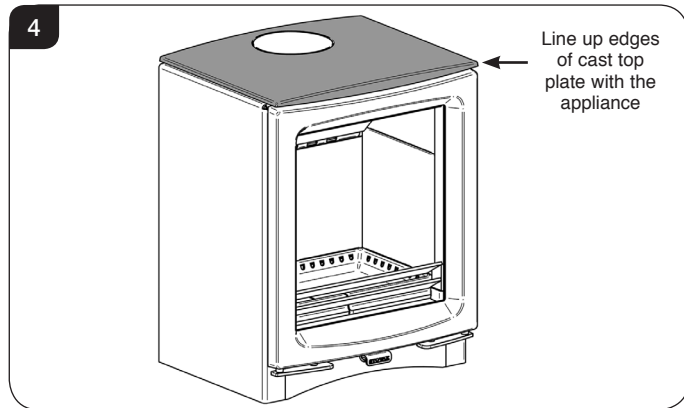

2.5 Connect appliance to the chimney using flue pipe.

2.6 Seal the connecting joints.

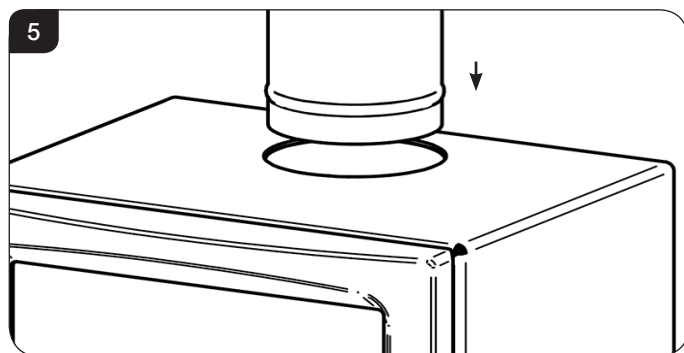

The Flue must be installed in accordance with manufacturers instructions.

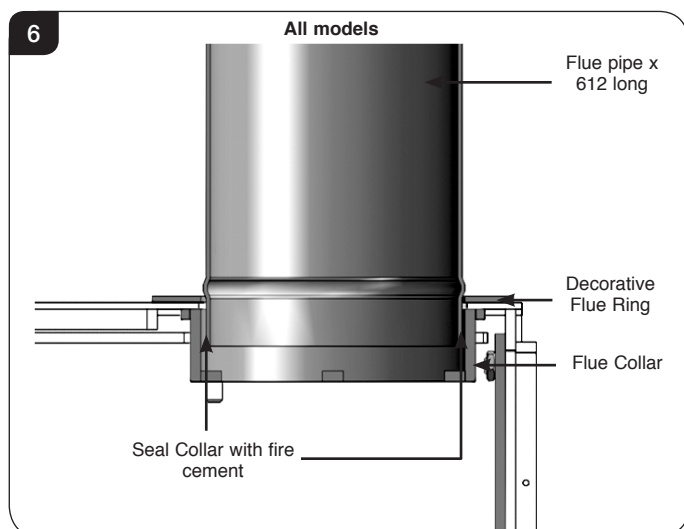

2.7 From the inside of the appliance, place a generous amount of fire cement inside the flue collar.

Place the decorative flue ring on the top of the appliance and line up with the flue hole.

Insert the 612mm long flue pipe into the flue collar so the bulge is sitting on the decorative flue ring.

2.8 Elevate the top plate whilst the flue pipe is sealed with fire cement.

When complete lower the top plate onto the appliance.

NOTE: THE DECORATIVE RING MUST NOT BE FITTED.

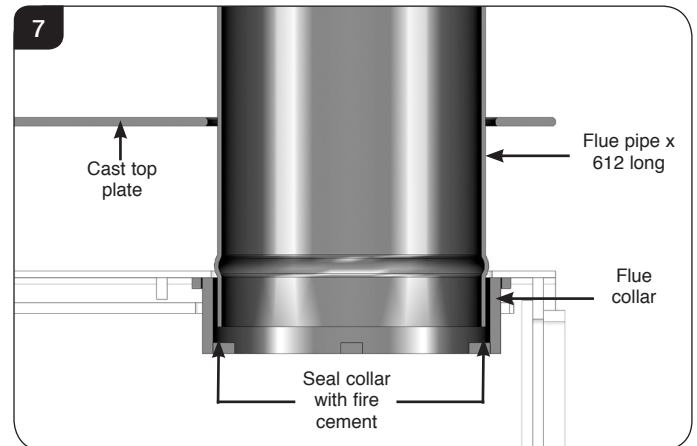

A Typical Top Flue Pipe Installation

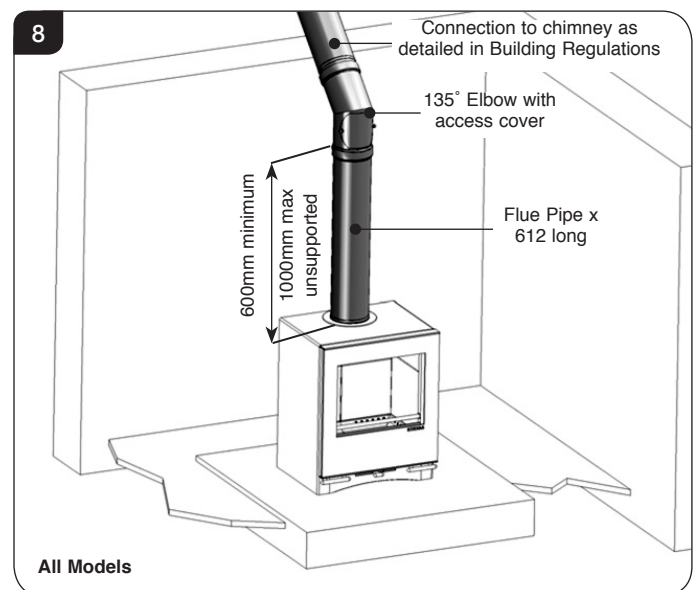

Installation Instructions

3. Rear Flue Installation

Because the appliance is supplied for top flue exit, the blanking plate will need to be moved to the top of the appliance and the collar and flue pipe fitted to the rear:

3.1 Tools required - cross-headed screw driver, 13mm A/F spanner/socket wrench.

3.2 To change from top to rear exit flue, reverse the flue collar and blanking plate using the method detailed:

- Remove the upper and lower baffles.
- Remove the top fire bricks.

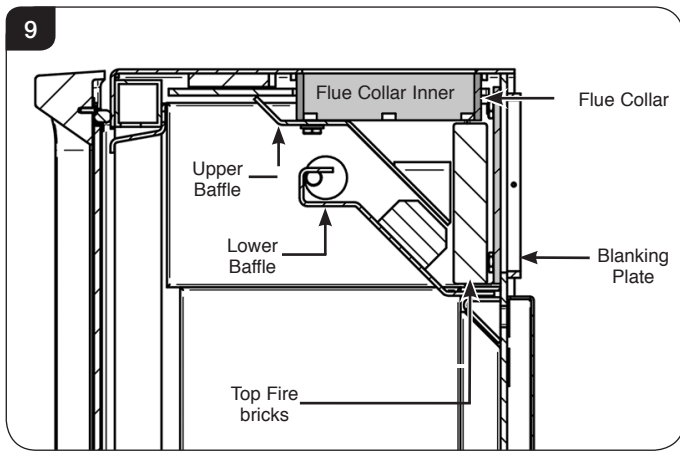

3.3 First remove the **deflector plate**.

- Use a 13mm A/F spanner/socket to remove 1 M8 half nut from each of the front two studs. The flanged spacer will drop down.
- Remove a further M8 nut from each front stud, see Diagram 10, Detail A Front.

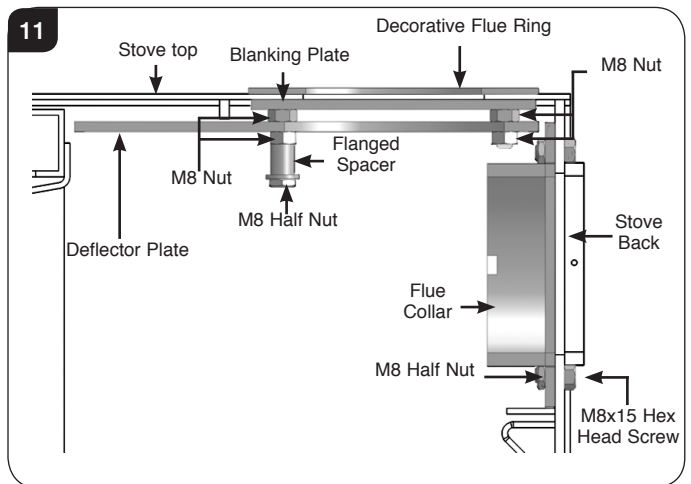
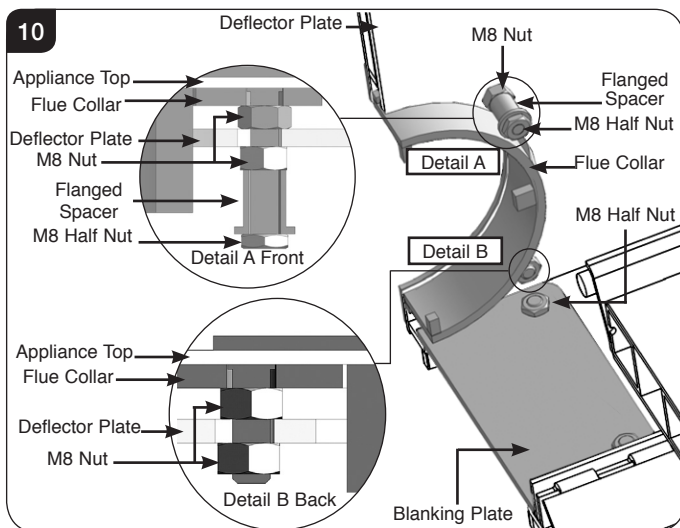

- Remove 1 M8 nut from each of the rear studs using a 13mm A/F spanner/socket. The deflector plate will drop down inside the appliance, see Diagram 10, Detail B Back.

3.4 Remove the **blanking plate** using a 13mm A/F Spanner/Socket wrench to take off the 4 M8 half nuts from the inside back plate of the appliance. Withdraw the blanking plate from inside and remove the 4 M8x15 Hex head screws from the back of the appliance.

3.5 To remove the **flue collar** remove the 4 M8 nuts front and back. The collar will then drop down inside the appliance.

3.6 Fitting the flue collar and blanking plate for rear flue:

- Fit the blanking plate to the top flue outlet using 4 M8 nuts.
- Seal to the firebox using fire cement.
- Slide the deflector plate through the 4 studs on the underside of the appliance top.
- Line up with the flue hole and secure in position using 2 M8 nuts onto the 2 front studs (reverse of removal).
- Fit the flue collar to the rear flue outlet using the 4 bolts and half nuts from the cover plate.
- Seal to the firebox using fire cement, see Diagram 2.
- Secure the deflector plate in position by fitting the two M8 Nuts onto the rear studs.
- Slide the flanged spacers over the two front studs and secure tightly using 2 M8 half nuts.
- Re-install upper and rear baffle.

Installation Instructions

3.7 The following flue pipe is available to ensure safe installation:

5" Tee	Stovax Product Code 4516
6" Tee	Stovax Product Code 4616
5" 135° Bend	Stovax Product Code 4512
6" 135° Bend	Stovax Product Code 4512
5" Flue Pipe x 612mm long	Stovax Product Code 4501
6" Flue Pipe x 612mm Long	Stovax Product Code 4601

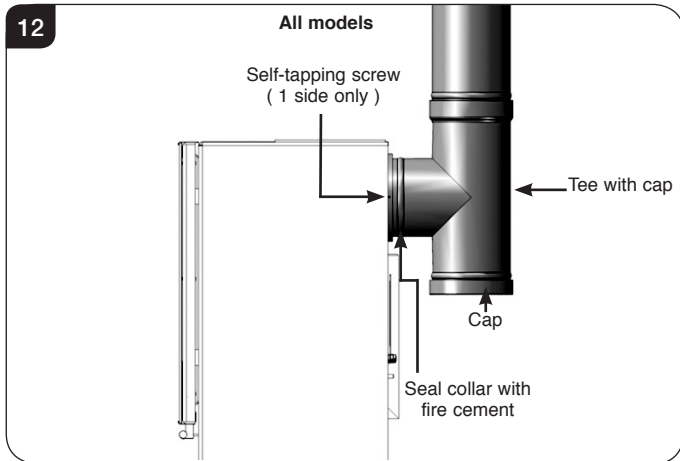

3.8 A Typical Rear Flue Pipe Installation

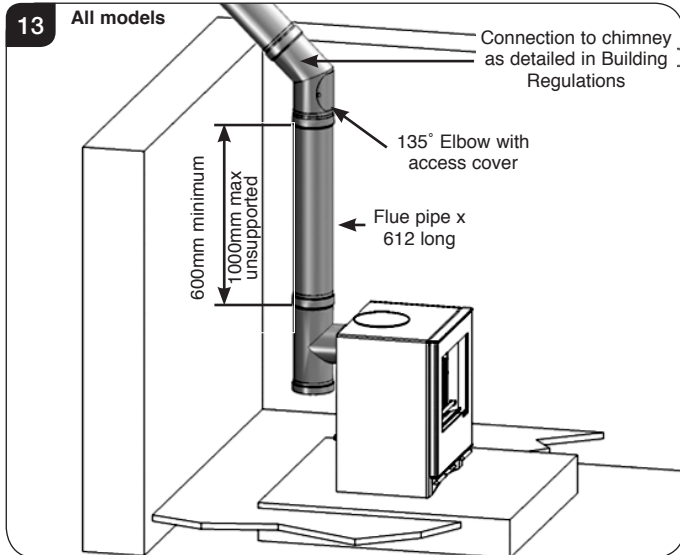

3.9 Line up the cast top flush with the front and sides of the appliance.

3.10 Fit the cast plug into the flue hole.

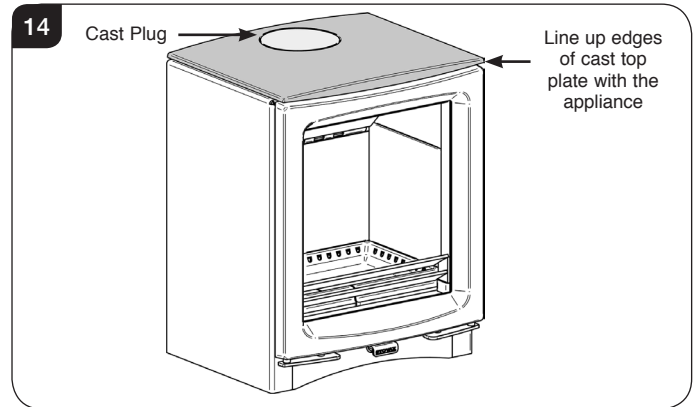

4. Cast Plinth - Optional

This appliance can be fitted with two optional decorative plinths:

Standard Plinth	VG-MID-BP
Midline Plinth	VG-MID-BML

The installation method is the same for both plinths.

To install the plinth:

- 4.1 Decide on the position of the appliance on the hearth.
- 4.2 Secure the plinth to the hearth using the 2 holes in the plinth back and suitable fasteners.

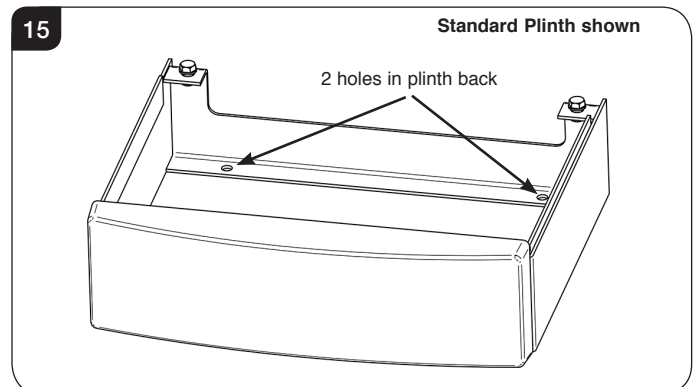

Installation Instructions

- 4.3 The plinth front is removable. It is advisable to remove this before fitting the appliance to the plinth.

Lift the plinth front so that the cast panel clears the 2 slots on the plinth to remove, see Diagram 16.

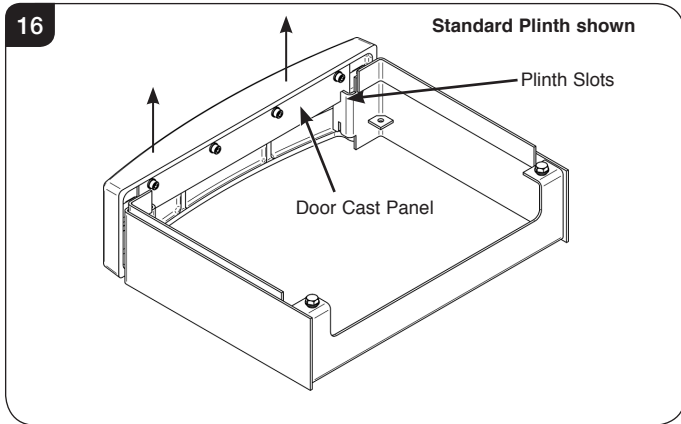

- 4.4 Lift the appliance onto the plinth:

— Line up the 2 side plinth braces with the 4 plinth spacers (two each side) on the inside of the appliance.

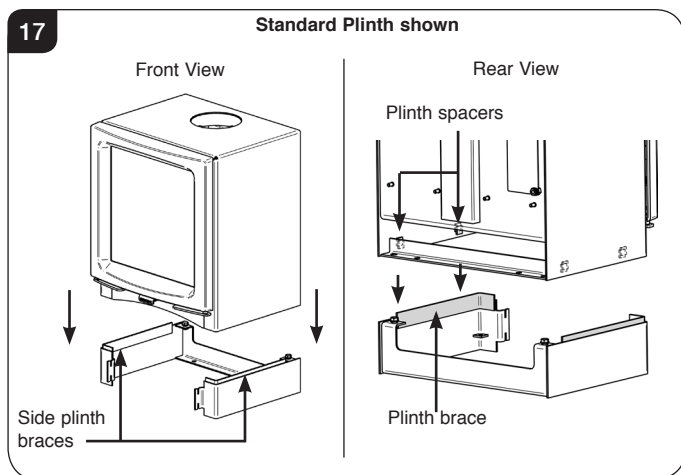

Ensure the sides and front of the appliance are sitting level and flush with the plinth.

- 4.5 Fix the appliance to the plinth using the 2 M8 screws and 2 M8 washers provided.

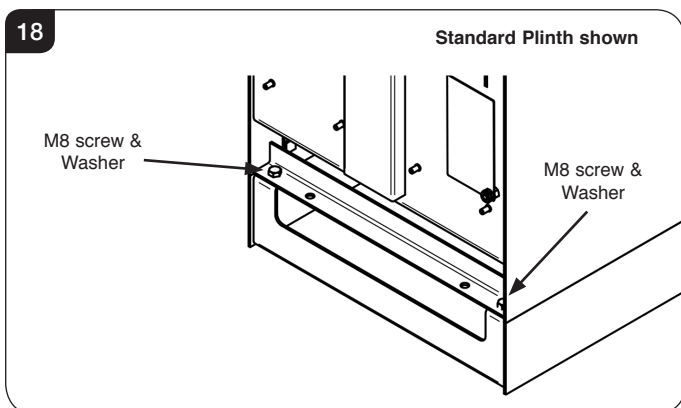

- 4.6 Locate the cast panel in the 2 fixing slots to fit the plinth front, see Diagram 19.

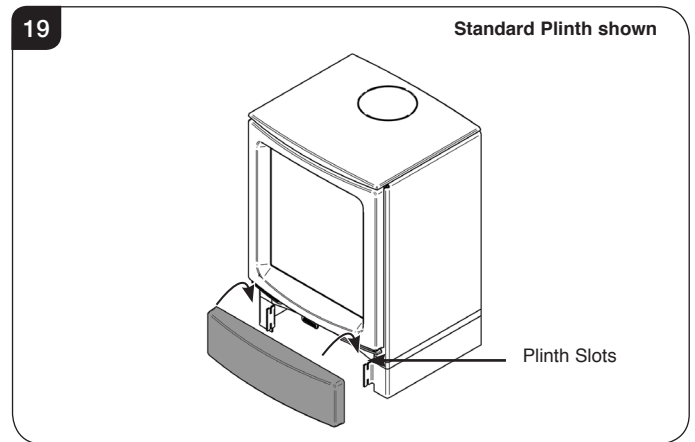

6. Smoke Control Kit



This appliance is supplied with a pre-fitted smoke control kit and has been independently tested to PD6434 making it exempt from the controls that generally apply in Smoke Control Areas.

THE SMOKE CONTROL KIT IS SUPPLIED DISABLED AND MUST THEREFORE BE MODIFIED BEFORE INSTALLATION, IN ORDER FOR THE APPLIANCE TO MEET THE REQUIREMENTS OF A SMOKE CONTROL AREA AND MUST BE OPERATED CORRECTLY IN ORDER TO MINIMISE THE AMOUNT OF SMOKE PRODUCED.

If this appliance is installed outside of a Smoke Control Area then the Smoke Control kit can be left disabled to give more control over the lower burn rates.

Any modifications to the kit should only be done by a suitably qualified installer and must be done at the time of installation.

- 6.1 This appliance is suitable for use in a Smoke Control Area when burning wood and following the instructions for use specified in this manual but **ONLY** if the Smoke Control kit has been enabled.

MODIFICATION WILL NEED TO BE CARRIED OUT PRIOR TO INSTALLATION OF THE APPLIANCE.

Installation Instructions

- 6.2 To access the Smoke Control Kit, carefully tip the appliance onto its back.
- 6.3 When the Smoke Control Kit is disabled the stub points downwards, see Diagram 20 A. The appliance can not be used in a Smoke Control Area.

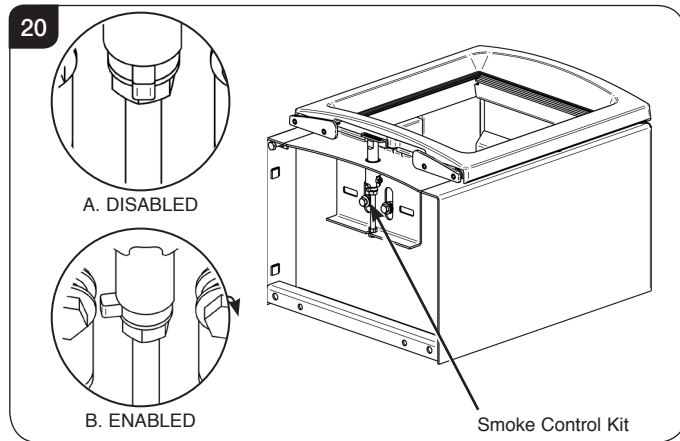

To enable the Smoke Control Kit:

- 6.4 Twist the control 90° either way to enable the Smoke Control Kit, see Diagram 20 B.
- 6.5 Tighten the nut to secure. The appliance can now be used in a Smoke Control Area.

7. Secondary Air Control

The Secondary Air is factory set to a nominal setting suitable for most chimneys. If required, this can be adjusted to suit local conditions.

WARNING: DO NOT close off completely, this may cause an excessive build up of pressure. Consult a qualified installer if you are experiencing problems with the flue system (see Troubleshooting, page 12).

- 7.1 The Secondary Air Control is located on the back of the appliance, see Diagram 21.

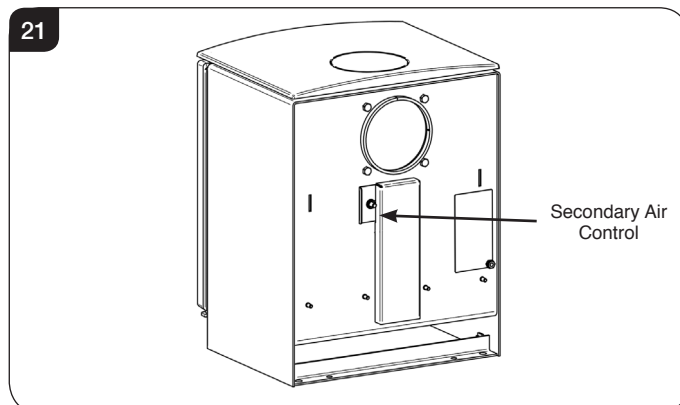

To adjust the Secondary Air Control:

- 7.2 Undo the nut shown in Diagram 22.

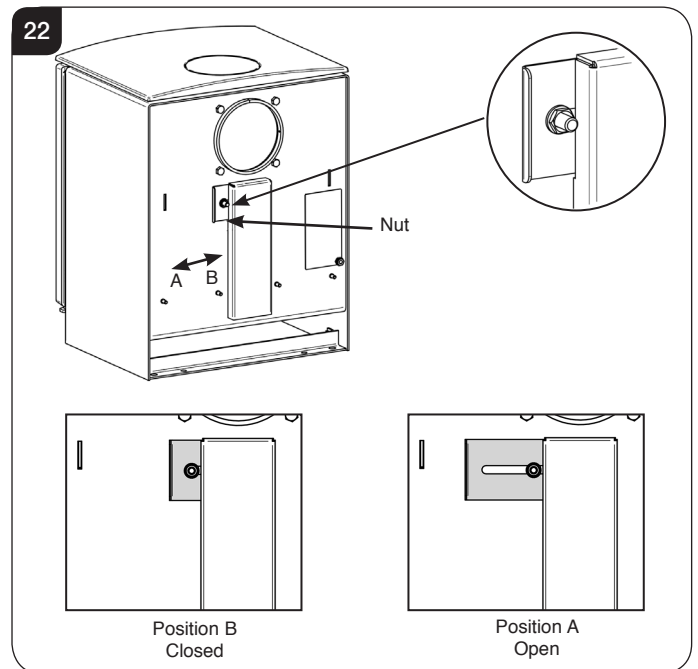

- 7.3 Pull the slider out to increase the amount of Secondary Air, see Diagram 21 A.
- 7.4 Push the slider in to reduce the amount of Secondary Air, see Diagram 21 B.
- 7.5 Once the required adjustment has been achieved, tighten the 2 nut to secure the slider.

8. Outside Air Kit

This appliance can be fitted with an optional kit to help bring air directly into the appliance from outside. For installation and operating procedures refer to the instructions supplied with the Outside Air kit - Stovax Part No PM373.

9. CO Alarms

All open flued appliances can be affected by temporary atmospheric conditions which may allow fumes to enter the house. **Building regulations require that whenever a new or replacement fixed solid fuel or wood/biomass appliance is installed in a dwelling a carbon monoxide alarm must be fitted in the same room as the appliance. Further guidance on the installation of the carbon monoxide alarm is available in the latest edition of BS EN50292 and from the alarm manufacturer's instructions.**

HETAS recommend the unit is permanently fixed in accordance with the manufacturer's installation instructions or with the guidance contained in Approved Document J where no other information is available.

Provision of an alarm must not be considered a substitute for either installing the appliance correctly or ensuring regular servicing and maintenance of the appliance and chimney system.

Commissioning

Commissioning

1.1 To commission:

- Replace the internal components.
- Check the door alignment and catch operation and adjust if required (see *Maintenance & Servicing Section 5*).
- Check the soundness of door seals, castings and joints.
- Check the operation of the air controls.

1.2 Now carry out a final smoke draw test:

- Warm the flue with a blowlamp, or similar, for about 10 minutes.
- Place a smoke pellet on the centre of the grate, with the air controls open.
- Close the door. Smoke should now be drawn up the flue and be seen to exit from the flue terminal.
- Complete test with all doors and windows closed in the room where the appliance is fitted.
- If there are any extractor fans in adjacent rooms the test must be repeated with the fans running on maximum and with interconnecting doors open.
- Check the effect of ceiling fans during the test.

If the test fails, re-check the suitability of the flue system and ventilation. An inadequate air supply to the room is potentially dangerous.

- Light the appliance and slowly increase the temperature.
- Ensure no combustion products enter the room.
- Open the main fire door when the appliance reaches operating temperature and carry out a spillage test with a smoke match or pellet around the door opening.

1.3 If excessive spillage occurs allow the appliance to cool and re-check the flue system and ventilation.

1.4 Finally:

- Explain to the user the safe operation of the appliance, use of the controls and the importance of only using suitable fuels.
- Ensure that a CO alarm has been fitted and make the user aware of its operation and importance, referring them to the Warning section on page 5 of the User Instructions.
- Explain the cleaning and routine maintenance requirements.
- Explain the requirement to use a suitable fireguard when children, elderly or infirm persons are near the appliance.
- Record retailer/supplier and installer details in Appliance Commissioning Checklist (page 3, Instructions for Use).
- Record serial number in Appliance Commissioning Checklist (page 3, Instructions for Use).

This number is required when ordering spare parts and making warranty claims.

- Give this instruction manual to the customer.

Certificate Of Compliance

Upon completing the installation, the form below must be filled in by your installer to comply with the requirements of HETAS and the building regulations. The installer must give these details, including their HETAS registration number, for the purposes of any insurance details that may change as a result of the appliance being installed.

HETAS LTD - CERTIFICATE OF COMPLIANCE

PLEASE TICK APPROPRIATE BOXES OR ENTER DETAILS IN BOXES BELOW



Record ID (HETAS Use Only)	<input type="text"/>	(*indicates that this data must be given)
Customer Name	*	
Installation Address	*	
Installation Address		
Installation Address		
Installation Address		
Town	*	
Postcode	*	Work Completion Date *
Local Authority Name (*Must be given if no postcode available)		
Installing Company Name	*	Company's HETAS Reg. No. *
Installing Engineer's Name	*	Engineer's HETAS Reg. No. *

Description of Work

Location:
 Lounge Dining Room Kitchen Utility Room Bedroom Other, Specify

Appliance: Dry Open Fire Open Fire with Boiler Dry Cooker Cooker with Boiler
 Dry Roomheater/Stove Roomheater/Stove with Boiler Independent Boiler
 Make Model Heat Output kW

System: New Heating and Hot Water System Updated Existing Heating and Hot Water System Dry System Only

If Wet System: Is the Hot Water System Unvented? Y N

Chimney: New Insulated Factory Made Chimney System Installed

Relining of existing chimney: Twin Wall Flexible Liner (for Class 1 Appliance) Cast In-situ Liner
 Rigid Sectional Liner Metal Rigid Sectional Liner Other

Hearth: New Hearth/Surround fitted Existing Hearth Surround Updated

Additional Information

Connecting fluepipe: Diameter mm Socket joints upward and gas tight

Provision for sweeping chimney/fluepipe: Yes No Chimney Data Plate Location

Air supply: Has a permanently open air vent been fitted: Yes No
 Is vent opening at least 50% of cross sectional area of throat/flue or State total free area of air vent mm²

Confirm an approved Carbon Monoxide alarm has been fitted

Testing & Commissioning to Approved J Appendix E

Confirm you have commissioned and tested the appliance & associated work for safe and efficient operation

Declaration of completion As the competent person responsible for the work described above, I confirm that the appliance and associated work has been installed in accordance with the HETAS rules of registration, and that the work complies with Regulations 4 and 7 of the Building Regulations, and Approved Documents J, G & L as applicable.

Signed: _____ Print name: _____ Date: _____

COPIES OF THIS COMPLETED CERTIFICATE MUST BE (WHITE COPY) SENT TO HETAS LTD AT THE ADDRESS GIVEN BELOW (PINK COPY) GIVEN TO THE CUSTOMER FOR RETENTION (YELLOW COPY) RETAINED BY THE INSTALLING COMPANY

**THIS CERTIFICATE SHOULD BE RETAINED BY THE PROPERTY OWNER
WHO MAY BE REQUIRED TO PRODUCE IT IN ANY FUTURE SALE OF THE PROPERTY.**

Maintenance & Servicing

For a complete list of spare parts and accessories contact your Stovax Retailer or call 01392 474011

1. Annual Service

- 1.1 Before the start of the heating season strip, inspect and clean the appliance as detailed:
- Allow appliance to cool.
 - Remove all internal parts: baffle, log guard and firebricks. Take care handling firebricks as they can become fragile after a period of use.
 - Sweep the appliance at this point if necessary.
 - Vacuum clean any remaining ash and debris from the inside of the appliance. Stovax offer a filter/collection attachment for vacuum cleaners to protect them from fire ash: Ash Clean (Stovax Part No. 2091).
 - Check the parts for any damage. Replace any damaged parts using genuine Stovax replacements parts.
 - Check and clean the firebricks with a soft brush. Some surface damage will occur during use. The life of the bricks will depend on the type of fuels burnt and the level of use. **Replace damaged bricks as soon as possible.**
 - Re-fit cleaned internal parts.
 - **On appliances with printed glass do not use cleaning agents that have a high alkaline or acidic content, for example Stovax Gel Cleaner, these are aggressive cleaning agents designed to be used with heavily stained clear glass. On printed glass surfaces, use Stovax Glass Cleaner (Stovax No.4103) which is better formulated for this application.**
- Do not use abrasive cleaners to remove tar or soot deposits from the glass.**
- Fit new door rope seal (see *Maintenance and Servicing, Section 4*).
 - Lightly oil the door catch mechanism and hinge pins. Avoid getting oil onto the door seals and glass.
 - To refresh painted finishes a touch up spray is available. Contact your Stovax retailer quoting the serial number found on the appliance data badge.

- 1.2 Use genuine Stovax replacement parts to keep the appliance in safe, efficient working order. This is a list of the maintenance products that may need be required:

Task	Product name
Preventing build-up of creosote in flue	Protector (15 sachets)
	Protector (1kg tub)
Sealing flue pipe joints	Fire Cement (500g tub)
	Fire Cement (600g cartridge)
Re-painting	Touch Up Aerosol (150ml aerosol)
Protecting your hands	Heat resistant leather gloves
Thermic seal glue	(50ml bottle)
Ash Clean	Vacuum Cleaner Attachment
Cleaning Glass	Gel Cleaner
	Glass Cleaner (Stovax no. 4103)

These products, available online at www.stovax.com or from your local Stovax Retailer, along with regular maintenance and use of correct fuels, will keep the appliance in the best possible condition.

- 1.3 For more information about the Stovax Group products please visit our web site at www.stovax.com.
- 1.4 Burn at a low temperature for the first day of use after any maintenance. This allows the seals, fixing glues and paint to fully cure.
- 1.5 During this time the appliance may give off some unpleasant odours. Keep the room well ventilated to avoid a build-up of fumes.
- 1.6 Your Stovax Retailer can carry out service and maintenance.

2. Removal of Internal Parts

- 2.1 To service and maintain the good working condition of your appliance it will be necessary to remove several internal parts. Consult the installation section for the following:

Log Guard - Pre-Installation Section 2, page 18.

Baffles - Pre-Installation Section 3, page 18.

Firebricks - Pre-Installation Section 4, page 19.

Maintenance & Servicing

3. Fitting a new Door Glass

- 3.1 To maintain the safe use of your appliance you may need to replace a damaged door glass.
- 3.2 Using the appliance with a damaged door glass could cause dangerous fumes to enter the room, or the appliance to over-fire, resulting in damage.

To do this:
- 3.3 Remove the round door rope.
- 3.4 Remove the 4 glass clips that the door rope was sat in, by unscrewing the screws around the edge.
- 3.5 The glass can be lifted out and replaced.
- 3.6 Take note of the roping around the edge of the door glass around the edge. This will also need replacing.

4. Fitting a new Door Seal

To maintain the safe use of the appliance damaged or worn door sealing rope must be replaced.

NOTE: Some discolouration and flattening of the seal will occur in normal use and this does not indicate a damaged seal.

To do this:

- 4.1 Remove the door from the appliance, by opening the door and lifting the door free of the hinge blocks on the left hand side of the door.
- 4.2 Lay the door face down on a soft flat surface, to protect the paintwork and glass.
- 4.3 Remove the old rope and scrape old glue from the locating groove.
- 4.4 Clean the locating groove with a clean dry cloth to remove all old dust and debris.
- 4.5 Squeeze a generous bead of fresh Stovax Thermic Seal glue into the rope locating groove.
- 4.6 Press the new Stovax rope into the locating groove, placing the joint in the middle of the lower edge of the door, see Diagram 1.

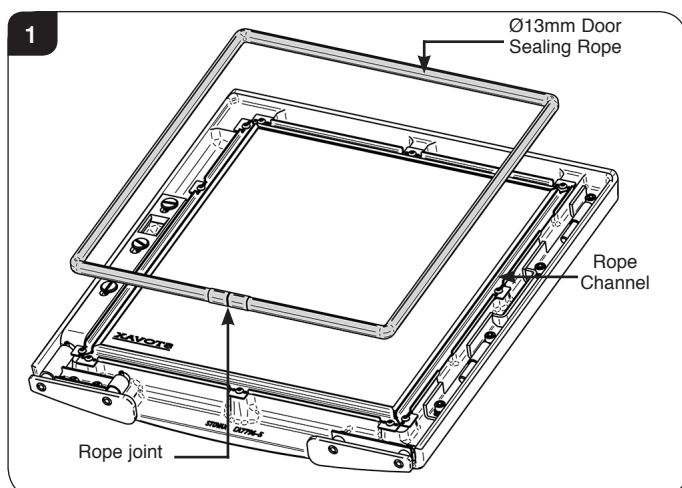

- 4.7 Refit the door and close the door to apply pressure to the new rope.
- 4.8 Leave the door(s) closed for at least 12 hours before lighting the appliance and run at a low temperature for approximately one day. This allows the adhesive to fully bond to the seal.
- 4.9 Using the appliance with a damaged door seal can cause dangerous fumes to enter the room, or the appliance to over fire, resulting in damage.

5. Adjusting the Door Hinges

- 5.1 To maintain the safe use of your appliance, you may need to adjust the door hinges to ensure the door closes safely and correctly.

The door can be adjusted in 2 different places:

- 5a Door Hinge Pin Assembly.
- 5b Hinge Blocks on Firebox.

5a. Door Hinge Pin Assembly

To adjust the **Door Hinge pin assembly**:

- 5a.1 Remove the door from the appliance, by opening the door and lifting the door free of the hinge blocks on the left hand side of the door.
- 5a.2 Lay the door face down on a soft flat surface, to protect the paintwork and glass.
- 5a.3 Use the hinge pin assembly on the back of the door to adjust the position of the door in relation to the appliance.

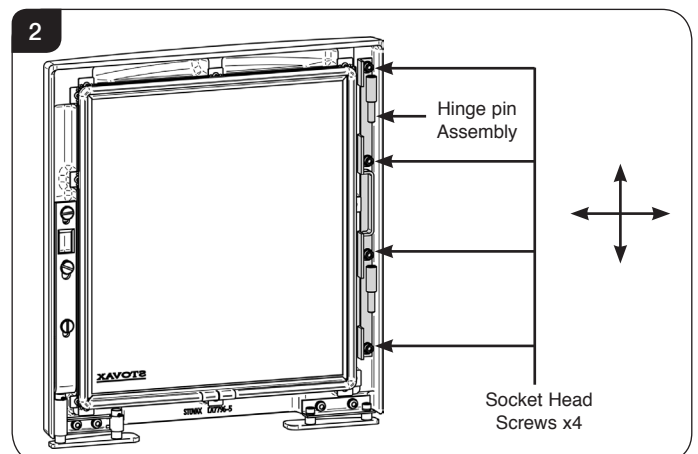

- 5a.4 Use a 5mm Hex Key to loosen the 4 socket head screws. The hinge pin assembly is slotted so it can be adjusted up or down and sideways approximately 3mm.
- 5a.5 Once the desired position has been achieved ensure the dome nuts are firmly tightened against the hinge block assembly to maintain the position.

Maintenance & Servicing

5b. Hinge Blocks on Firebox

To adjust the **Hinge Blocks on the Firebox**:

- 5b.1 Use a 5mm Hex Key to loosen the screws, see Diagram 3. This allows front to back adjustment to allow the seal between the door and firebox to be improved, if required.

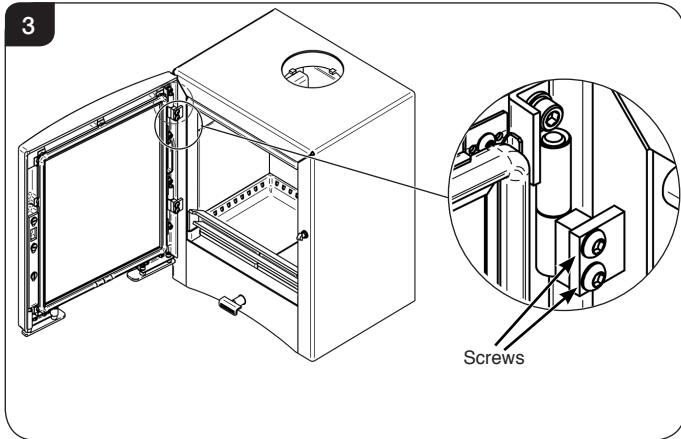

- 5b.2 Once the desired position has been achieved ensure the screws are firmly tightened.

6. Adjusting the Door Catch

To adjust the **Door Catch**:

- 6.1 Open the door to gain access to the catch.

If the door cannot be opened with the handle/ multifunctional tool, pull the door with one hand and carefully insert a small flat head screwdriver into the slot in the door catch slider, see Diagram 4.

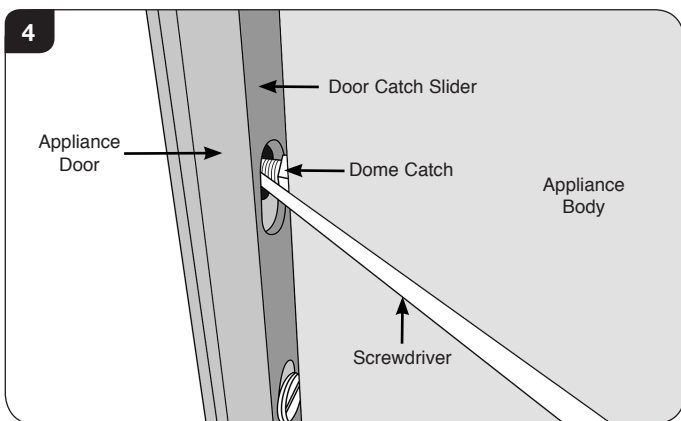

Lift the door catch slider until it disengages from the dome catch and the door opens.

- 6.2 Use a 13mm A/F spanner to loosen the half lock nuts either side of the box section in the appliance body. This will allow the dome catch to rotate in and out, see Diagram 5.

DO NOT undo the catch more than 3-4mm.

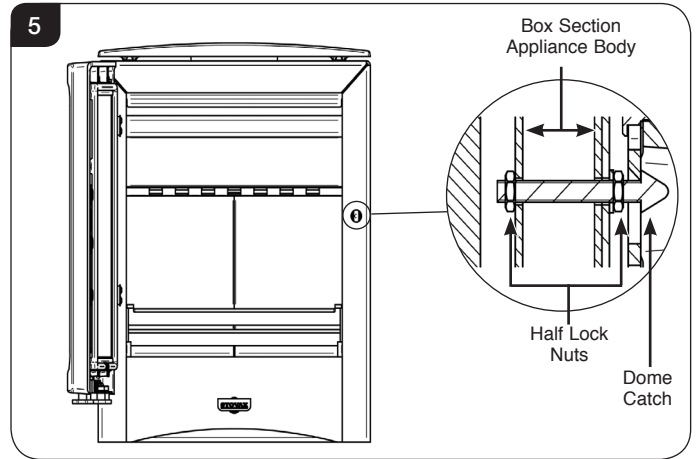

- 6.3 Ensure the dome catch is in an upright position with the flat sides parallel with the side of the appliance, see Diagram 6.

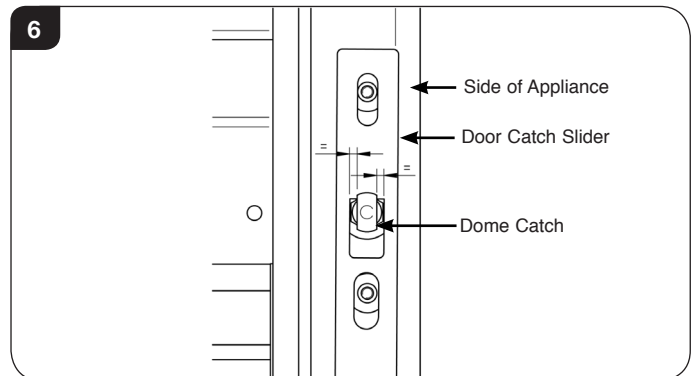

When the door closes the Dome Catch should sit centrally in the slot of the door catch slider.

- 6.4 Adjust the height of the catch so that the door locking mechanism makes contact slightly above the point of the Dome Catch, see Diagrams 7, 8 & 9.

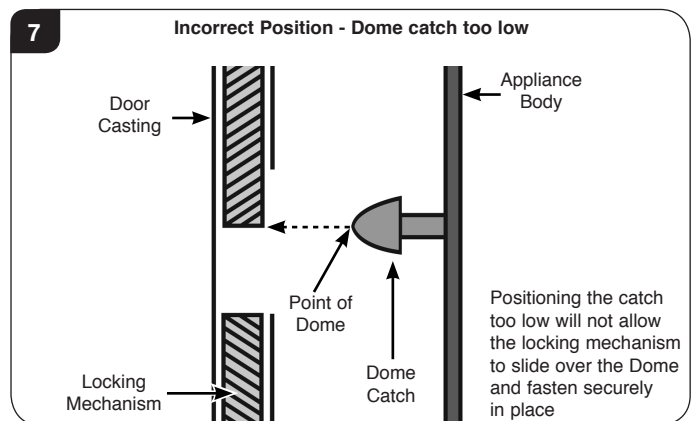

Maintenance & Servicing

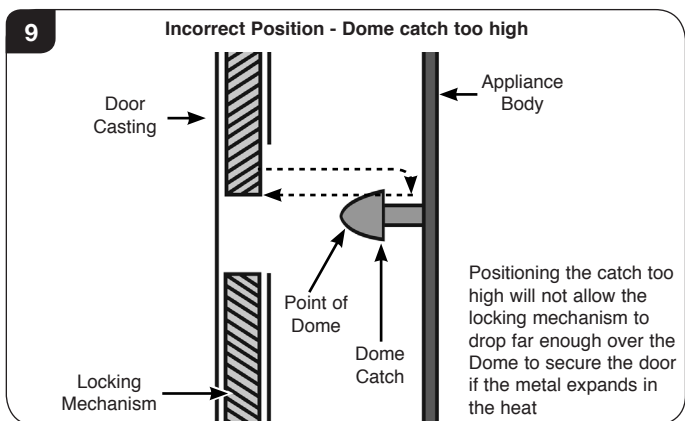
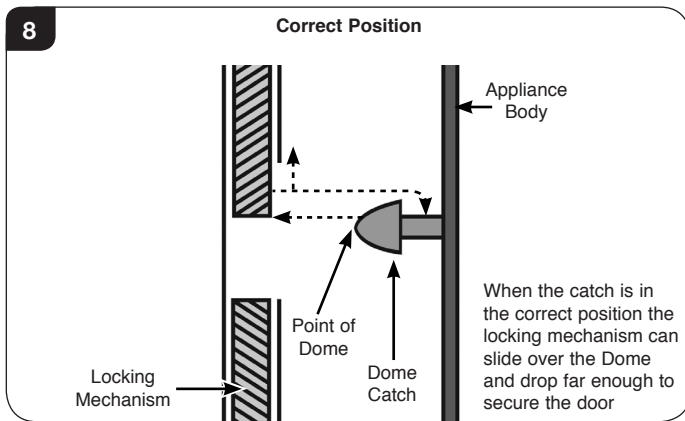

- 6.5 To ensure a firm hold by the locking mechanism, the catch should be positioned to allow the maximum distance of travel up and down over the tapered end of the catch.

Note: If the point of the Dome Catch is in line with the bottom of the locking mechanism this will prevent the door from being pushed closed, too high and the catch won't travel far enough down the other side of the catch to hold the door if the metal expands when hot.

- 6.6 Fully tighten the lock nuts to secure the Dome Catch.
- 6.7 Open and close the door several times to check the adjustment.

7. Final Checks

- 7.1 Following these adjustments check that the door:
- Does not come into contact with the log guard.
 - Can be pushed shut without operating the door handle.
 - Passes the paper sealing test.
 - Aligns with the side and top of the appliance.

Technical Appendix

Legal Requirements

Before installation and/or use of this appliance please read these instructions carefully to ensure that all requirements are fully understood.

The appliance must be fitted by a registered installer*, or approved by your local building control officer.

It is very important to understand the requirements of the national Building Regulations† and standards‡, along with any local regulations and working practices that may apply. Should any conflict occur between these instructions and these regulations then the regulations must apply.

Your local Building Control Office can advise regarding the requirements of the regulations.

i † England and Wales – Document J / Scotland - Part F/Document J (Republic of Ireland only)
‡ the latest edition of BS 8303, BS EN 15287, BS 7566

*Registered on the Competent Persons Scheme (GB only) see page 35/ INFO (Republic of Ireland).

Works must be carried out with care to meet the requirements of Health and Safety† and comply with the Health and Safety rules**, and any new regulations introduced during the lifetime of these instructions. Particular attention should be drawn to:

- **Handling:** The appliance is heavy. Adequate facilities must be available for loading, unloading and on site handling.
- **Fire Cement:** Some fire cement is caustic and must not come into contact with the skin. Protective gloves must be worn. Wash hands thoroughly with plenty of water after contact with skin.
- **Asbestos:** This appliance contains no asbestos. If there is the possibility of disturbing any asbestos in the course of installation seek specialist guidance and use appropriate equipment.
- **Metal Parts:** Take care when installing or servicing the stove to avoid personal injury.

A faulty installation can cause danger to the inhabitants and structure of the building.

For users of this appliance:

Your building insurance company may require you to inform them that a new heating appliance has been installed on your property. Check that your cover is still valid after installing the appliance.

1. Flue Outlet Positions

These positions are defined by Document J of the Building Regulations.

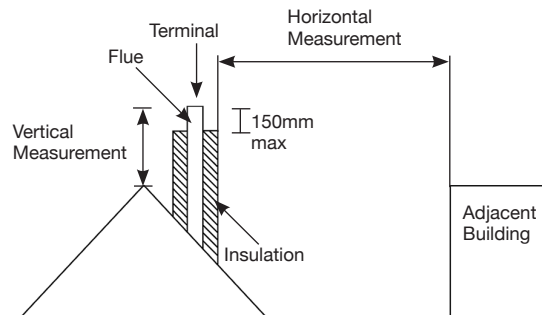
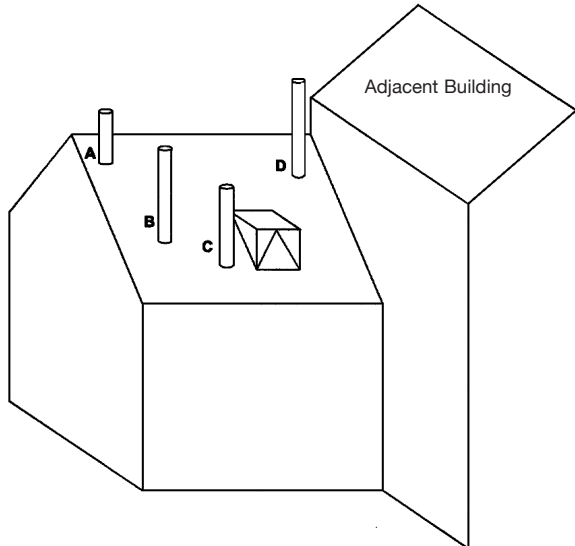

The datum for vertical measurement is the point of discharge of the flue from either the point of discharge of the flue or 150mm above insulation, whichever is the lower.

IMPORTANT: Seek specialist advice if installing in a dwelling with a thatched roof

Point where the flue passes through weather surface (Notes 1 & 2)	Clearances to flue outlet
A	At or within 600mm of the ridge
B	At least 600mm above ridge
B	At least 2300mm horizontally from the nearest point on the weather surface and: a) at least 1000mm above highest point of intersection of the chimney with and the weather surface; or b) at least as high as the ridge
C	At least 1000mm above the top of opening
C	Below (on a pitched roof) or within 2300mm horizontally to openable rooflight, dormer window, or other opening (Note 3)
D	At least 600mm above any part of the adjacent of building within 2300mm
D	Within 2300mm of an adjoining or adjacent building, whether or not beyond the boundary (Note 3)

1) The weather surface is the building external surface, such as it's roof tiles or external walls.
2) A flat roof has a pitch less than 10°.
3) The clearance given for A or B, as appropriate, will also apply.
4) A vertical flue fixed to an outside wall should be treated as equivalent to an inside flue emerging at the nearest edge of the roof.

Technical Appendix - Flues

2. Flue or Chimney

2.1 The flue or chimney system must be in good condition. It must be inspected by a competent person and passed for use with the appliance before installation.

Products of combustion entering the room can cause serious health risks.

2.2 The following must be checked:

— The construction of the masonry chimneys, flue block chimneys and connecting flue pipe system must meet the requirements of the Building Regulations†.

— A flexible flue liner system can be used if certified for use with solid fuel systems and installation complies with manufacturer's instructions and Building Regulations. The flue liner must be replaced when an appliance is replaced, unless proven to be recently installed and in good condition.

— If it is necessary to fit a register plate it must conform to the Building Regulations†.

— The minimum height of the flue or chimney must be 4.5m from the hearth to the top of the flue, with no horizontal sections and a maximum of 4 bends. Bends must have angles of less than 45 degrees from the vertical.

— There should be at least 600mm of vertical flue pipe above the appliance before any bends are introduced.

— Ensure the connecting flue pipe is kept a suitable distance from any combustible material and does not form part of the supporting structure of the building.

— The installer must ensure the flue pipe diameter is not less than the diameter of the outlet of the appliance and does not narrow to less than the size of the outlet at any point in the system.

— Make provision to remove the appliance without the need to dismantle the chimney.

— Any existing flue must be confirmed as suitable for the new intended use as defined in the Building Regulations.

— The flue or chimney systems must be inspected and swept to confirm the system is structurally sound and free from obstructions.

— If the chimney is believed to have previously served an open fire it must be swept a second time within a month of regular use after installation to clear any soot falls that may have occurred due to difference in combustion levels.

— The flue exit from the building must comply with local building control rules†.

— Chimney heights and/or separations may need to be increased in particular cases where wind exposure, surrounding tall buildings, high trees or high ground could have adverse effects on flue draught.

— Do not connect or share the flue or chimney system with another heating appliance.

2.3 Do not connect to systems containing large voids or spaces over 230mm square.

2.4 Suitable access must be provided to enable the collection and removal of debris.

2.5 The flue must be swept and inspected when the appliance is installed.

Flue Draught

The flue draught must be checked with all windows and doors closed and any extraction fans in this, or adjoining rooms, running at maximum speed (see Installation Checklist for ventilation requirements).

Twin Wall Flue System

If this appliance is to be used in conjunction with a twin wall flue system then Stovax recommend the use of their Professional XQ range. Details of this product are available from your Stovax retailer.



In the U.K:

*BS En 15287-1, and the requirements of Building Regulations

**This should be done by a NACS registered (UK only)/INFO registered (Eire only) chimney sweep, who will issue you with a certificate.

† Building Regulations Document J

Flue Plate:

Where a hearth, fireplace, flue or chimney is provided or extended (including cases where a flue is provided as part of refurbishment work), information essential to the correct appliance and use of these should be permanently posted in the building, to meet Requirement J4 of the Building Regulations (England and Wales), F3.12 (Scotland).

Additional:

A new factory made system that complies to EN 1856; Part 1 can be used providing installation is to the requirements of:

- i) BS 7566 Parts 1 -4
- ii) the manufacturer's instructions
- iii) Building Regulations.

For a guide containing information on Chimneys and Flues contact:

The British Flue & Chimney Manufacturers' Association,
FETA
2 Waltham Court
Milley Lane
Hare Hatch
Reading
Berkshire RG10 9TH

Tel: 0118 9403416

e-mail: info@feta.co.uk

Ventilation - Technical Appendix

3. Ventilation

3.1 Many older buildings are sufficiently ventilated by natural leakage of air to provide suitable air supply for an appliance of 5kW output or less.

Modern building techniques have reduced the amount of air that leaks in or out of a house. A modern construction with an air tightness of less than 5m³ per hour per m² requires an air vent for **ALL** solid fuel appliances including those with a rated heat output of less than 5kW.

NOTE: The air leakage of a modern house is tested at the completion of construction and a certificate issued confirming this.

- 3.2 This appliance requires a constant supply of air to maintain proper combustion and effective flue performance.
- 3.3 An inadequate air supply can result in poor combustion and smoke entering the room which is potentially dangerous.
- 3.4 This supply of air can come from either:
- Purpose provided ventilation.
 - Some Stovax appliances can also be fitted with an optional outdoor air kit which allows air to be drawn in from the outside.
- 3.5 The amount of air required must comply with local building regulations and the rules in force.
- 3.6 If spillage is detected during commissioning then there may be insufficient natural ventilation and an additional air supply will be necessary.
- 3.7 Permanent air vents should be non-adjustable and positioned where they are unlikely to become blocked.
- 3.8 If vents open into adjoining rooms or spaces there must be an air vent of at least the same size direct to the outside.
- 3.9 Site the vents where cold draught is unlikely to cause discomfort. This can be avoided by placing vents near ceilings or close to the appliance (See diagram).
- 3.10 Extractor fans or cooker hoods must not be placed in the same room or space as this can cause the appliance to emit fumes into the room.
- 3.11 Increase air supply provisions where a room contains multiple appliances.
- 3.12 **If any checks reveal problems do not proceed with the fitting of the appliance until they have been rectified.**

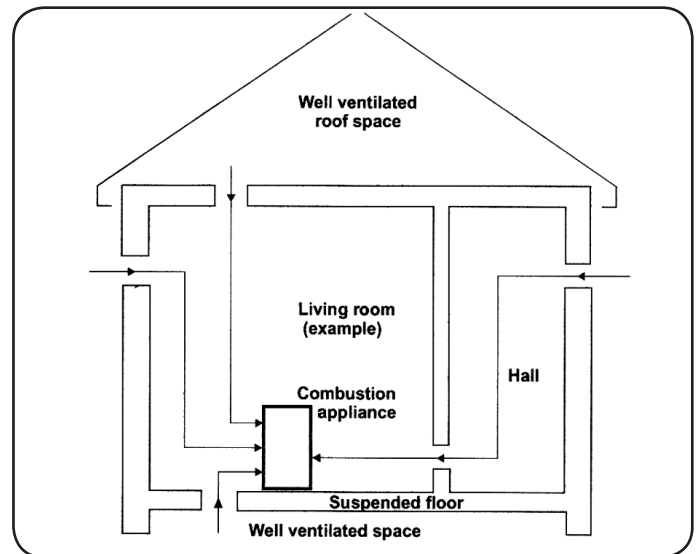

4. Minimum Dimensions - Hearth

- 4.1 The appliance must stand on a non-combustible constructional hearth which is at least 125mm thick with the minimum dimensions as shown in diagram. As this appliance can be installed in an elevated setting it is recommended to increase the 225mm hearth depth to safely contain any falling logs or embers. The higher the appliance is installed the deeper the hearth should be to protect the floor.
- 4.2 The building must have a suitable load-bearing capacity for the hearth and appliance. Consult a structural engineer for advice before proceeding.
- 4.3 When fitting into an existing hearth check that the appliance complies with current construction regulations and is at least the minimum sizes shown.
- 4.4 If there is no existing fireplace or chimney it is possible to construct a suitable non-combustible housing and hearth setting. The flue must be installed in accordance with all local and national regulations and current rules in force.
- 4.5 Check if adding a new chimney to your property requires planning permission.
- 4.6 Some houses are built using a timber frame construction with high levels of thermal insulation. Isolate the appliance from combustible materials, and provide sufficient ventilation to maintain the heating efficiency.

5. Fitting Appliances On A Boat

- 5.1 If an appliance is to be fitted in a boat it must be done in accordance with the latest edition of BS 8511 (Code of Practice for the Installation of Solid Fuel Heating Appliances on Boats). The Code covers the design, installation and operation of solid fuel heating appliances that are suitable for fitting into inland waterway boats, and gives guidance on product selection, design considerations, installation requirements, inspection and testing, as well as maintenance and safe use tips.
- 5.2 Consideration should also be given to the requirements of the Boat Safety Scheme (BSS) to ensure the boat's insurance remains valid.
- 5.3 The appliance should only be installed by a competent person with experience of the latest edition of BS 8511 and the Boat Safety Scheme (BSS).
- 5.4 Secure the product to a suitably constructed non-combustible hearth.
- 5.5 All open flued appliances can be affected by temporary atmospheric conditions which may allow fumes to enter the boat. An electronic carbon monoxide detector conforming to the latest edition of BSEN50292 must be fitted and maintained.
- 5.6 Failure to safely install the appliance could endanger the boat and persons on board.



Organisations authorised to certify competence in the installation of domestic solid fuel appliances (Competent Persons Scheme):

APHC - Association of Plumbing and Heating Contractors (Certification) Ltd.
www.aphc.co.uk

BESCA - Building Engineering Services Competence Accreditation Ltd.
www.besca.org.uk

HETAS - Heating Equipment Testing and Approval Scheme Ltd.
www.hetas.co.uk

NAPIT - National Association of Professional Inspectors and Testers Ltd.
www.napit.org.uk

NICEIC - NICEIC Group Ltd.
www.niceic.org.uk

HETAS Approved Chimney Sweeps:

NACS - The National Association of Chimney Sweeps
www.chimneyworks.co.uk

APICS - The Association of Master Chimney Sweeps Ltd.
www.apics.org

The Guild of Master Chimney Sweeps -
guildofmasterchimneysweeps.co.uk

Basic Spare Parts

WOODBURNING STOVE

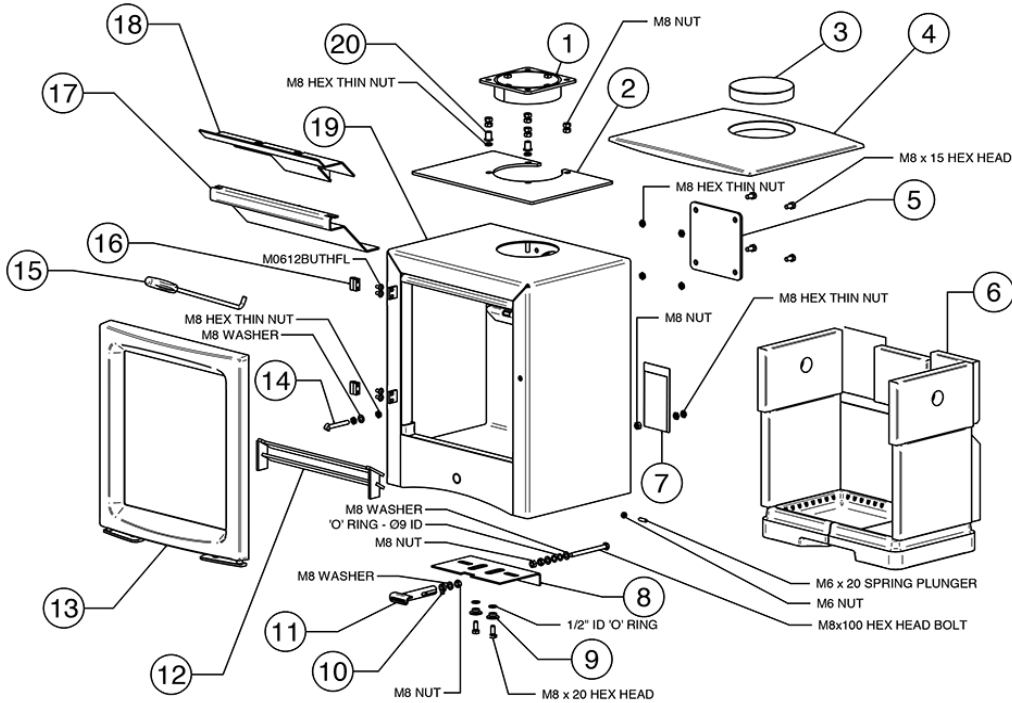

VOGUE

Ref.	Description
1	5" FLUE COLLAR
2	DEFLECTOR PLATE
3	CAST TOP PLUG
4	CAST TOP PLATE
5	FLUE BLANK
6	WOOD BRICK ASSEMBLY
7	DATA PLATE MOUNT
8	AIR CONTROL MAIN PLATE
9	AIR CONTROL TOP HAT
10	DEFRA SWITCH
11	AIR CONTROL HANDLE ASSEMBLY
12	LOG GUARD ASSEMBLY
13	CAST DOOR ASSEMBLY
14	MUSHROOM HEAD DOOR LATCH
15	RIDDLING/DOOR TOOL
16	ADJUSTABLE HINGE ASSEMBLY
17	LOWER BAFFLE
18	UPPER BAFFLE
19	CARCASS - WOOD
20	TOP HAT SPACER

DOOR ASSEMBLY

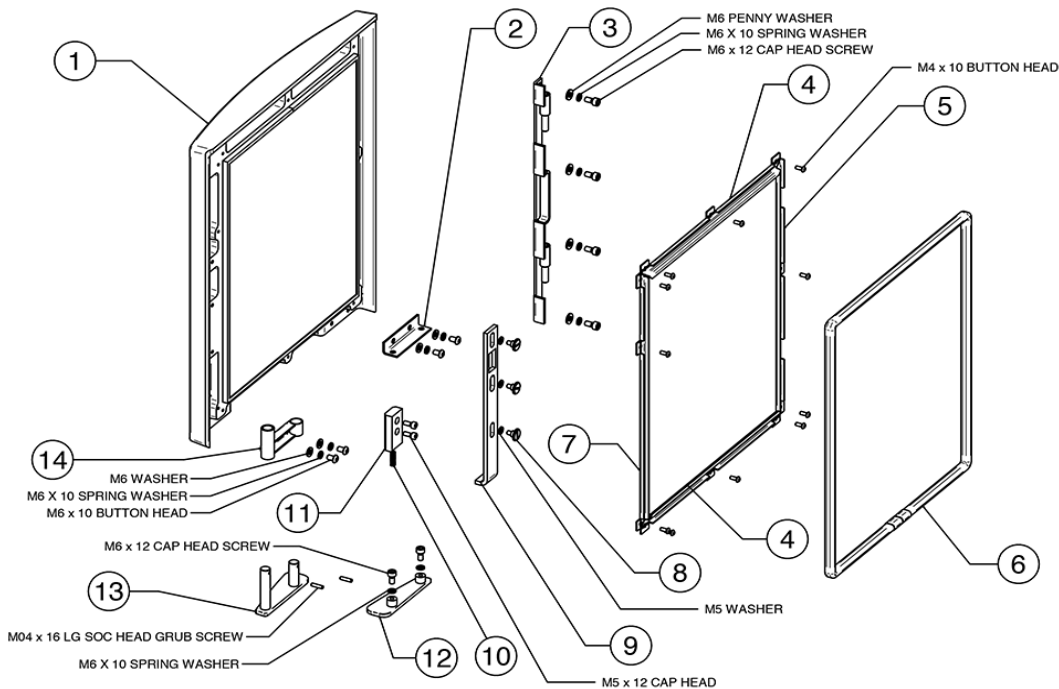

VOGUE

Ref.	Description
1	CAST DOOR
2	BRACKET
3	HINGE PLATE ASSEMBLY
4	TOP/ BOTTOM ROPE CHANNEL
5	HINGE SIDE ROPE CHANNEL
6	ROPE SEAL
7	LATCH SIDE ROPE CHANNEL
8	LARGE SHOULDER SCREW
9	DOOR CATCH SLIDER
10	SPRING
11	DOOR CATCH BLOCK
12	DOOR HANDLE ASSEMBLY LH
13	DOOR HANDLE ASSEMBLY RH
14	DOOR HANDLE BRACKET

Due to continual technical improvements please check online at www.stovax.com or with your Stovax retailer for the most up to date parts lists.

Basic Spare Parts

STANDARD PLINTH ASSEMBLY

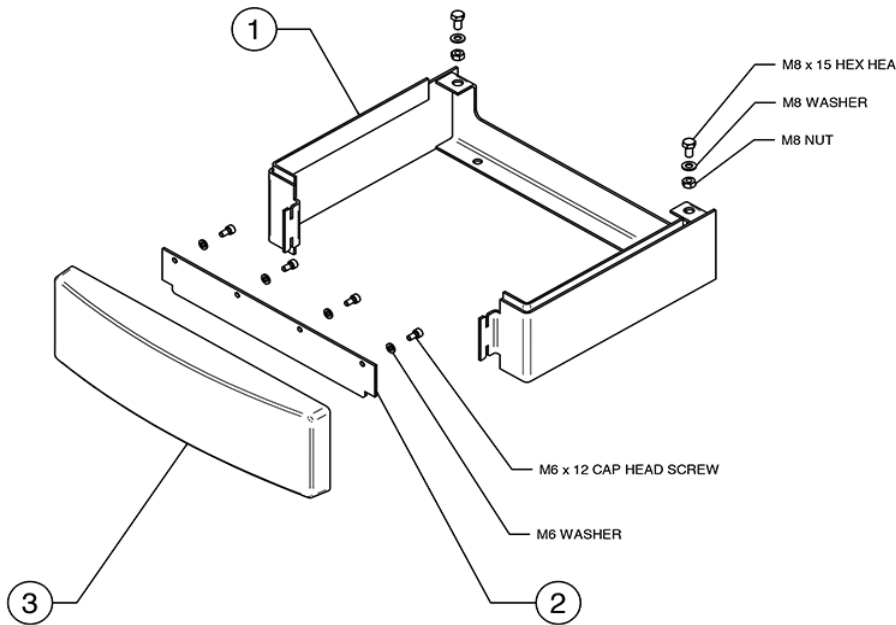

VOGUE STANDARD PLINTH

Ref.	Description
1	GLASS PLINTH FRAME ASSEMBLY
2	MOUNTING BRACKET
3	CAST PLINTH

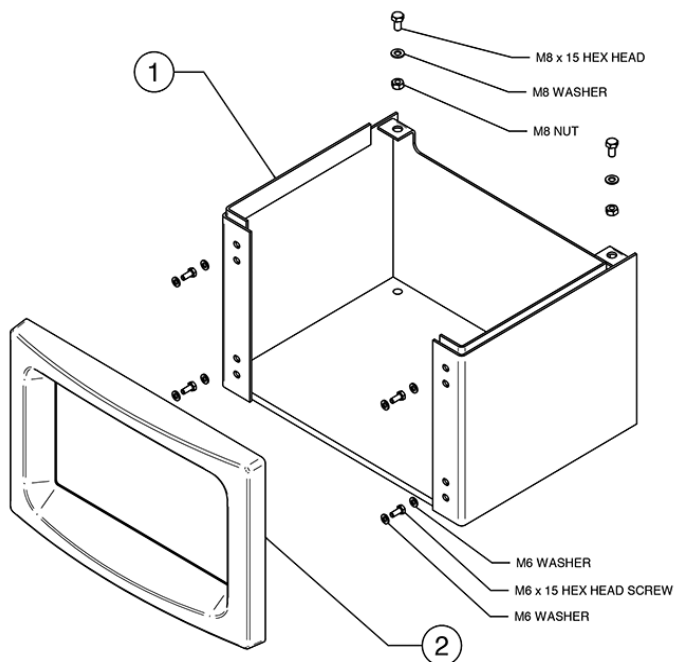

Due to continual technical improvements please check online at www.stovax.com or with your Stovax retailer for the most up to date parts lists.

Basic Spare Parts

BRICK ASSEMBLY - WOODBURNING

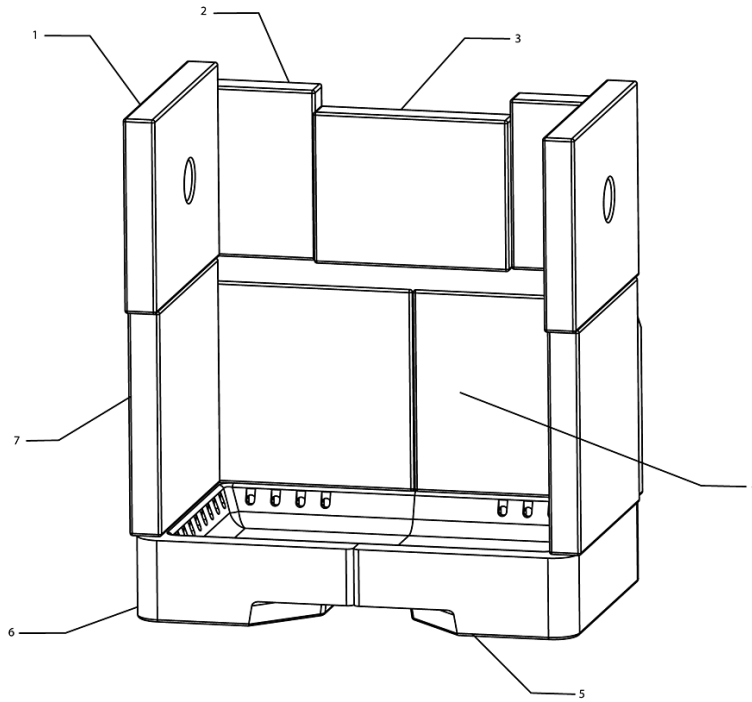

VOGUE

Ref.	Description
1	UPPER SIDE BRICK
2	UPPER REAR SIDE BRICK
3	UPPER CENTRE BRICK
4	LOWER REAR BRICK
5	RH BASE BRICK
6	LH BASE BRICK
7	LOWER SIDE BRICK

Due to continual technical improvements please check online at www.stovax.com or with your Stovax retailer for the most up to date parts lists.

Service Records

1ST SERVICE

Date of Service:.....

Next Service Due:.....

Signed:.....

Dealer's Stamp/HETAS Registration Number

3RD SERVICE

Date of Service:.....

Next Service Due:.....

Signed:.....

Dealer's Stamp/HETAS Registration Number

5TH SERVICE

Date of Service:.....

Next Service Due:.....

Signed:.....

Dealer's Stamp/HETAS Registration Number

7TH SERVICE

Date of Service:.....

Next Service Due:.....

Signed:.....

Dealer's Stamp/HETAS Registration Number

9TH SERVICE

Date of Service:.....

Next Service Due:.....

Signed:.....

Dealer's Stamp/HETAS Registration Number

2ND SERVICE

Date of Service:.....

Next Service Due:.....

Signed:.....

Dealer's Stamp/HETAS Registration Number

4TH SERVICE

Date of Service:.....

Next Service Due:.....

Signed:.....

Dealer's Stamp/HETAS Registration Number

6TH SERVICE

Date of Service:.....

Next Service Due:.....

Signed:.....

Dealer's Stamp/HETAS Registration Number

8TH SERVICE

Date of Service:.....

Next Service Due:.....

Signed:.....

Dealer's Stamp/HETAS Registration Number

10TH SERVICE

Date of Service:.....

Next Service Due:.....

Signed:.....

Dealer's Stamp/HETAS Registration Number



HETAS Approval

These appliances have been approved by HETAS as an intermittent operating appliance for burning dry seasoned wood logs.

Recommended Fuels

Please note that HETAS Appliance Approval only covers the use of dry seasoned wood logs and anthracite or manufactured briquette smokeless fuels on these appliances. HETAS approval does not cover the use of other fuels either alone or mixed with the recommended fuels, nor does it cover instructions for the use of other fuels.

STOVAX

Stovax Ltd, Falcon Road, Sowton Industrial Estate, Exeter, Devon, England EX2 7LF
Tel: (01392) 474011 Fax: (01392) 219932 E-mail: info@stovax.com www.stovax.com

E & O E