



COUNTRY LIVING

The Bembridge

WOOD BURNING STOVE FROM CHARNWOOD

Operating & Installation Instructions



COUNTRY LIVING

The Bembridge

WOOD BURNING STOVE FROM CHARNWOOD

CONTENTS

OPERATING INSTRUCTIONS

Fuel	5
Fitting The Wood Ash Removal Grate	5
Riddling	6
Lighting	6
Controlling The Fire	6
Refuelling	7
Ash Clearance	7
Reduced Burning	7
Maintenance	8
Throat Plate & Flueway Clearing	8
Chimney Sweeping	8
Trouble Shooting	8-9
CO Alarm	9
If you need further help	9

INSTALLATION INSTRUCTIONS

Unpacking The Stove	11
Health & Safety Precautions	11
CO Alarms	11
Specification	11
Chimney	11
Hearth & Fire Surround	12
Connection to Flues	13
Soot Doors	13
Pre Lighting Check	13
Commissioning	13
Clean Air Act Information	13-14
Certification	15
Dimensions	16
Parts List	17

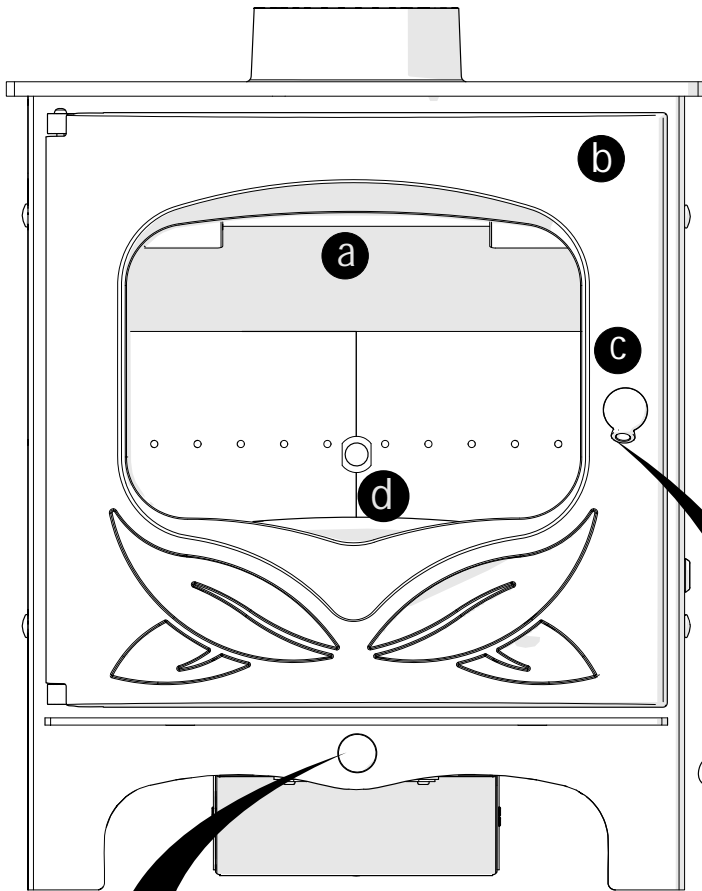

- a** Throat plate
Improves efficiency of stove by slowing down flue gases
- b** Door
Keep closed when stove is in use
- c** Door handle
Open with the supplied tool
- d** Fuel retainer
Ensure fuel does not protrude beyond retainer

Door Operation Tool

LIGHTING AND CONTROLLING THE FIRE

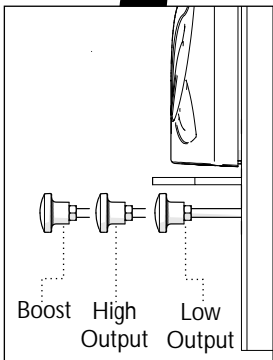

Air control

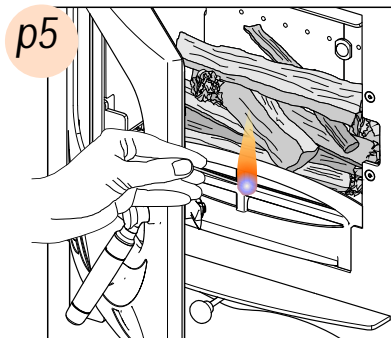

Add kindling and paper or firelighters. Keep air control fully out and close door

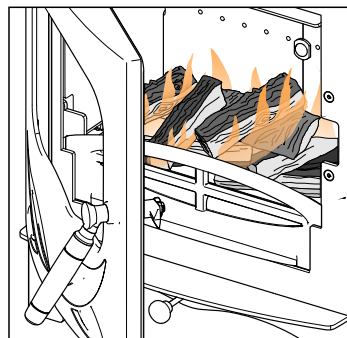

Once kindling is alight, add smaller logs. Keep air control fully out and close door

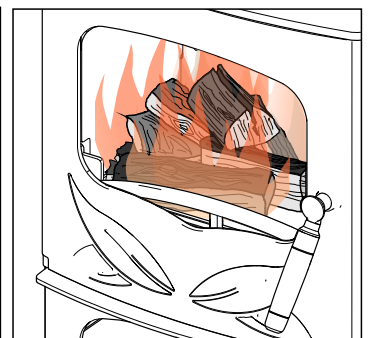

Add larger logs once fire is established. Air control can be reduced to medium

MAINTENANCE AND CLEANING

Glass	Wipe with damp, lint free cloth. Any stubborn deposits on the glass may be removed with a proprietary stove glass cleaner or ceramic hob cleaner
Throat plate	Take down once a month and clean. Sweep sooty deposits into fire
Chimney	Have chimney swept twice a year. Chimney can be swept through stove
Servicing	Stove should be serviced by a professional at least once a year

Suitable fuels for your Charnwood:
Wood logs

Unsuitable fuels:
Petroleum coke
Liquid fuel
Household waste
Coal singles
Small nuts or coal dust
Wet or unseasoned wood



Congratulations on becoming the owner of a Charnwood Bembridge Stove. Your stove has been approved by DEFRA to burn wood logs in a smoke control area if it is used in accordance with these instructions. It is therefore very important that you read and understand these instructions before using the stove.

Before lighting the stove check with the installer that the work and checks described in the Installation Instructions have been carried out correctly and that the chimney has been swept, is sound and free from any obstructions. The stove is not suitable for use in a shared flue system.

Remember that the stove will be hot and that it is made from hard materials - ensure that you have good balance before operating the fire. Always use the provided operating tool and gloves.

Do not use an aerosol spray on or near the stove when it is alight. There is a risk of explosion or flash ignition of the spray.

When using the stove in situations where children, aged and/or infirm persons are present a fireguard must be used to prevent accidental contact with the stove. The fireguard should be manufactured in accordance with BS 8423:2002.

The stove is suitable for intermittent operation.

FUEL

This stove has been designated to burn wood. Only dry well seasoned wood should be burnt on this appliance as burning wet unseasoned wood will give rise to heavy tar deposits in the stove, on the glass and within the chimney. For the same reason hard woods (such as Ash, Beech and Oak) are better than soft woods (such as Pine and Spruce). Burning wet unseasoned wood will also result in considerably reduced outputs. The wood should be cut and split and then left to season in a well ventilated dry place for at least one year but preferably two years before use. Approximate suitable log sizes are:

305mm(12in) long and 75mm (3in) diameter

PETROLEUM COKE IS NOT SUITABLE FOR USE ON THIS APPLIANCE. ITS USE WILL INVALIDATE THE GUARANTEE.

This stove is not designed to burn household waste.

For advice on other fuels please contact Charnwood.

OPTIONAL WOOD ASH REMOVAL GRATE

Wood can be burnt on the base. There is an optional wood ash removal grate available for ash clearance only.

Tools required for fitting the wood ash removal grate:

10mm Spanner

Pozidriv screwdriver

Before fitting the wood ash removal grate (Fig. 1) remove the fuel retainer and the wood ash retainer. The wood ash retainer is not required when the wood ash removal grate is fitted.

Undo the nut on the blanking hole using a 10mm spanner. Remove the cover and spacing washer (ensure you keep these in a safe place as you will need to replace them if the riddling grate is removed).

Feed the riddler rod through the hole on the right hand side of the stove, and slide one washer onto the rod (if there is not sufficient room to the right of the stove to do this then remove the riddler knob, fit one washer over the rod and then slide the rod through the hole from the inside of the stove).

Feed the rod through the two side fireplates and slide the other washer on to the rod so that the washers end up outside the two side fireplates. With the side fireplates pushed together fit the retaining clips so that the washers come inside the clips.

Slide the side fireplates apart so that they rest against the sides of the firebox. Slot in the front and rear support plates.

Fit the grate plates into position through the front and rear grate support plates, making sure they locate correctly onto the riddler rod. Fit the fuel retainer. Slide the ashpan under the grate.

Fig.1. Wood Ash Removal Grate

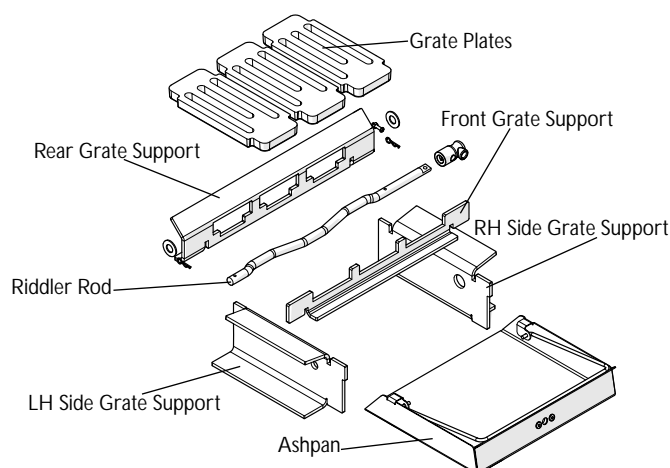



RIDDLING

Ash should be allowed to build up and only riddled when the ash bed begins to be too deep. The fire should be riddled with the door shut (see Fig. 2). Place the tool onto the riddling lever and rotate between the lower and horizontal positions several times. Too much riddling can result in emptying unburnt fuel into the ashpan and should therefore be avoided.

Fig.2. Riddling the wood ash removal grate

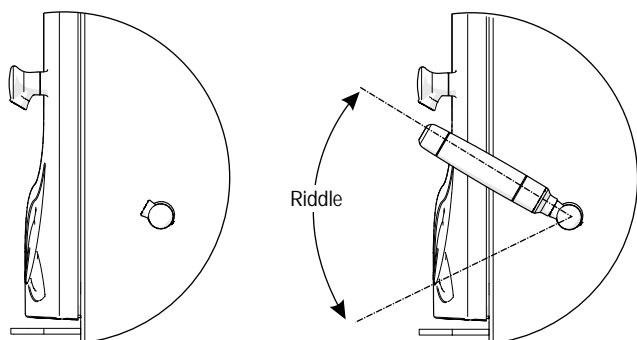

DOOR OPERATION

The door handle has been carefully designed to be removed from the stove during normal operation and re-fitted prior to loading and de-ashing. However, if you need to open the door when the fire is running at maximum then the additional use of a cloth or glove may be required.

Take care not to touch the door as it will be hot when the fire is burning. Turn the door handle anti-clockwise to open, and clockwise to close.

TOOL HOLDER

The operation tool can be stored in the fabric tool holder when not in use. This is supplied with a hook so it can be fixed to the wall.



LIGHTING

On initial lighting, the stove may smoke and give off an odour as the silicon paint with which the firebox is painted reacts to the heat. This is normal and will cease after a short time, but meanwhile the room should be kept well ventilated.

At first only light a small fire and burn it slowly for two hours to allow any residual moisture in the chimney to evaporate.

Light the stove using dry kindling wood and paper or fire lighters. Put the paper, or fire lighters, and kindling in the firebox and cover with a few small dry logs. Open the air control fully (see Fig. 3). Light the paper or fire lighters. The door may be left cracked open for a few minutes to assist the combustion and heat up the firebox more quickly. When the kindling wood is well alight add a few more small logs, close the door but leave the air control fully open. When the flames are established around these logs, load the stove with the required fuel load. Maintain the air control at maximum at this stage. Once the fire is up to temperature the airwash system will begin to work, so allow the fire to become hot before adjusting the air control to the required setting. During the lighting period, do not leave the stove unattended. Do not leave the door open except as directed above to avoid excessive smoke.

When relighting the stove, leave the ash on the base if burning wood, unless it is becoming too deep, in which case some of it may be removed.

CONTROLLING THE FIRE

The rate of burning and hence the output is controlled by the air control (see Fig. 3).

Fig.3. Stove Controls

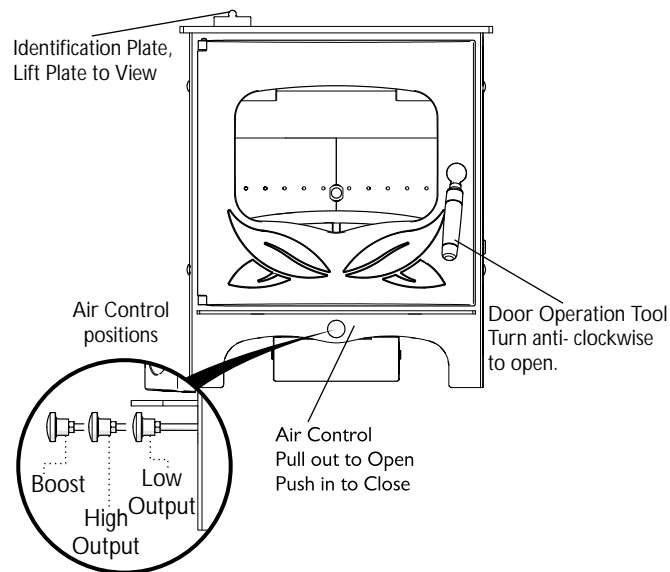

Open the air control fully (boost position) when lighting or when rapid burning is required. It should not be left fully open for long periods as this can cause over-firing or excessive smoke production. For high output move the air control to the 'click position' or for low burning to the fully closed position.



When the fire is burning normally the air control gives enough airwash to keep the glass clean. However, it will not always be possible to keep the glass clean with the air control fully closed. For correct firing we recommend the use of a stove pipe thermometer which may be purchased from your supplier or from Charnwood.

REFUELLING

Keep the firebox well filled but do not allow fuel to spill over the top of the fuel retainer.

Logs should be evenly distributed, filling the firebed to give the most pleasing flame pattern. The air control must be fully opened after refuelling until the flames are established above the fire. It is best to refuel on to a hot bed of embers. If at this point the fire starts to die, the door must be cracked open until the fire is revived. If the fire has started to die down before refuelling, then more kindling wood must be added, the air control opened fully and the door cracked open to re-establish the firebed *before* adding larger logs (see suitable log sizes in Fuel section). This will avoid excessive smoke emission.

Care should be taken, especially when burning wood, that fuel does not project over the fuel retainer or damage to the glass may be caused when the door is closed. It can also cause the glass to blacken up. Maximum filling height is such that logs cannot fall from the fire when the door is opened.

ASH CLEARANCE

For optimum wood burning, it is important to leave a layer of ash around 1cm thick on the base of the stove. Before removing ash ensure that it has cooled down, scoop out the remaining ash and empty into a metal container. Please avoid emptying hot ash into plastic liners or bins.

To make ash removal easier there are scoops and ash carriers available. These may be purchased from your supplier or, in case of difficulty, from Charnwood.

Fig.4.Ash Removal

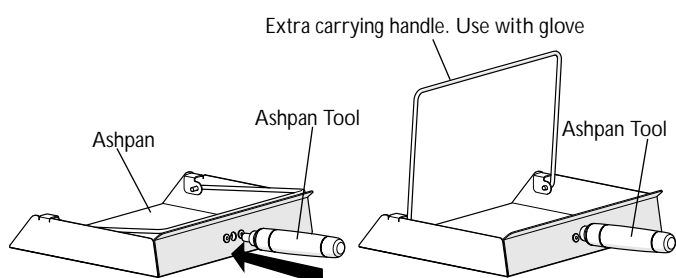

If an Optional Wood Ash Removal Grate is fitted, the Ashpan should be emptied regularly before it becomes too full. Never allow the ash to accumulate in the ashpan so that it comes in contact with the underside of the grate as this will seriously damage the grate bars.

The ashpan is handled using the Door Opening tool and gloves provided. Ensure that the tool is fully engaged before lifting (See Fig.4). When carrying the ashpan, it should be kept horizontal and supported by the carrying handle to prevent it falling off the tool.

REDUCED BURNING

For reduced burning the fire door must be closed.

When burning wood in areas that are not smoke controlled, load some large logs on the fire and allow to burn for half an hour before closing the air control (this will help to reduce tar deposits in the chimney). Some experimentation may be necessary to find the setting most suitable for the type of fuel being used and the draw on the chimney.

MAINTENANCE

Cleaning

The stove is finished with a high temperature paint which will withstand the temperatures encountered in normal use. This may be cleaned with a damp lint-free cloth when the stove is cold. Should re-painting become necessary, high temperature paints are available from your supplier or from stove shops.

Cleaning the Glass

Most deposits on the glass may be burnt off simply by running the fire at a fast rate for a few minutes. If it becomes necessary to clean the glass then open the door and allow it to cool. Clean the glass using a damp cloth and then wiping over with a dry cloth. Any stubborn deposits on the glass may be removed with a proprietary stove glass cleaner or ceramic hob cleaner. Do not use abrasive cleaners or pads as these can scratch the surface which will weaken the glass and cause premature failure

When Not in Use

If the fire is going to be out of use for a long period (for instance in the summer) then to prevent condensation, and hence corrosion, the air control should be left fully open and the fire door left ajar. It is also advisable to sweep the chimney and clean out the fire. Spraying the inside of the door and firebox with a light oil, such as WD40, will also help to keep all internal parts working well. After long periods where the fire has been out of use, the chimney and appliance



flueways should be cleaned before lighting.

Door Seals

For the fire to operate correctly it is important that the door seals are in good condition. Check that they do not become worn or frayed and replace them when necessary.

Servicing

It is recommended that the fire is serviced once a year to keep it in first class working order. After cleaning out the firebox thoroughly, check that all internal parts are in good working order, replacing any parts that are beginning to show signs of wear. Check that the doors seals are in good condition and that the door seals correctly. A servicing guide is available on request. Repairs or modifications may only be carried out by the Manufacturer or their approved agents. Use only genuine Charnwood replacement parts.

THROAT PLATE AND FLUEWAY CLEANING

It is important that the throat plate and all the stove flueways are kept clean in order to prevent potentially dangerous fume emission. They should be cleaned at least monthly, and more frequently if necessary. It is necessary to let the fire out to carry out these operations.

To remove the throat plate, slide it forwards so that it clears the back brick, then slide it either right or left so that the opposite side clears the top of the side brick and can be gently lowered. Any sooty deposits should then be swept from the plate and into the fire.

Return the throat plate to its correct position- At an angle, insert the throat plate so that it sits on top of either the right or left side brick. Raise the opposite side and slide so that the throat plate is central and supported by both side bricks. Slide back so that the throatplate rests neatly on the top of the back bricks.

Fig.5. Throat Plate Position and Lowering

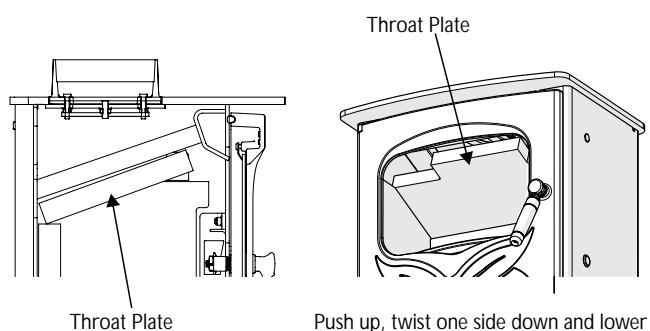

CHIMNEY SWEEPING

Where the chimney previously served an open fire, it is possible that the higher flue gas temperature from a stove may loosen soot deposits with the consequent risk of flue blockage. It is therefore recommended that the chimney be swept a second time within a month of regular use after installation.

The chimney should be swept at least twice a year. Where the top outlet or vertical rear flue connector is used it will generally be possible to sweep the chimney through the appliance.

First remove the fuel retainer and the throat plate. Then sweep the chimney ensuring that soot is removed from all horizontal surfaces after sweeping.

In situations where it is not possible to sweep through the appliance the installer will have provided alternative means, such as a soot door. After sweeping the chimney the appliance flue outlet and the flue pipe connecting the stove to the chimney must be cleaned with a flue brush.

After clearing any soot from within the stove, replace the throat plate (see Fig. 5) and the fuel retainer.

Different types of sweep' s brushes ae available to suit different flueways. For prefabricated insulated chimneys the manufacturers instructions with regard to sweeping should be consulted.

TROUBLE SHOOTING

Fire Will Not Burn

Check that:

- the air inlet is not obstructed in any way,
- chimneys and flueways are clear,
- a suitable fuel is being used,
- there is an adequate air supply into the room,
- an extractor fan is not fitted in the same room as the stove.
- there is sufficient draw in the chimney. Once the chimney is warm a draught reading of at least 1.25 mm (0.05 in.) water gauge (12Pa) should be obtained.

Blackening of Door Glass

Differences in chimney draughts mean that the best settings of the air controls will vary for different installations. A certain amount of experimentation may be required, however the following points should be noted and with a little care should enable the glass to be kept clean in most situations:



- a) Wet or unseasoned wood, or logs overhanging the front fence will cause the glass to blacken.
- b) The airwash relies on a supply of heated air to keep the glass clean, therefore, when lighting the stove allow the firebed to become well established before closing the air control. This may also be necessary when re-fuelling the stove.
- c) When re-fuelling keep the fuel as far back from the front fence as possible, do not try to fit too much fuel into the firebox.
- d) Do not completely close the air control.

It is always more difficult to keep the glass clean when running the stove very slowly for long periods.

If blackening of the glass still occurs check that all flue connections and the blanking plate are well sealed. It is also important that the chimney draw is sufficient and that it is not affected by down-draught. When the chimney is warm a draught reading of at least 1.25 mm (0.05 in.) water gauge (12Pa) should be obtained. Some blackening of the glass may occur below the level of the fuel retainer. This will not obscure the view of the fire or affect its performance.

Fume Emission

Warning Note:

Properly installed and operated this appliance will not emit fumes. Occasional fumes from de-ashing and re-fuelling may occur. Persistent fume emission is potentially dangerous and must not be tolerated. If fume emission does persist, then the following immediate actions should be taken:

- a) Open doors and windows to ventilate the room and then leave the premises.
- b) Let the fire out and safely dispose of the fuel from the appliance.
- c) Check for flue or chimney blockage, and clean if required.
- d) Do not attempt to re-light the fire until cause of fuming has been identified, if necessary seek professional advice.

The most common cause of fume emission is flueway or chimney blockage. For your own safety these must be kept clean.

Fire blazing out of control

Check that:

- a) The door is tightly closed.
- b) The air control slider is fully closed.
- c) A suitable fuel is being used.

- d) Door seals and airwash slide are intact.

Chimney Fires

If the chimney is thoroughly and regularly swept, chimney fires should not occur. However, if a chimney fire does occur close the air control, and tightly close the door of the appliance. This should cause the chimney fire to go out in which case the controls should be kept closed until the stove has gone out. The chimney and flueways should then be cleaned. If the chimney fire does not go out when the above action is taken then the fire brigade should be called immediately. After a chimney fire the chimney should be carefully examined for any damage. Expert advice should be sought if necessary.

CO ALARM

Your installer should have fitted a CO alarm in the same room as the appliance. If the alarm sounds unexpectedly, follow the instructions given under "Warning Note" above.

IF YOU NEED FURTHER HELP

If you need further help with your Charnwood then your Installer will be able to provide the answers to most questions. Your Local Charnwood Premier Dealer has a great deal of experience and will also be able to provide helpful advice. Further help is available from the Charnwood Customer Services department who will be pleased to give advice, if necessary.





UNPACKING THE STOVE

The stove arrives bolted and strapped to its pallet. There must be adequate facilities for unloading and manoeuvring into position. The wrapping is first removed, then the stove released from the pallet by removing 4 pallet bolts using a 10mm spanner. The pallet brackets can now be removed from the stove by tilting it and using a 13mm spanner to remove the bolts. These 4 bolts are required for levelling or fixing on the Store Stand. The Stove may now be moved to its final position. The pallet is intended to be cut up and used for kindling fuel.

HEALTH AND SAFETY PRECAUTIONS

Please take care when installing the stove that the requirements of the Health and Safety at Work Act 1974 are met.

Some types of fire cement are caustic and should not be allowed to come into contact with the skin. In case of contact wash with plenty of water.

If there is a possibility of disturbing any asbestos in the course of installation then please use appropriate protective equipment.

There must not be an extractor fan fitted in the same room as the stove as this can cause the appliance to emit fumes into the room.

There must be an adequate air supply into the room in which the appliance is installed to provide combustion air. The combustion air supply must be via a permanently open vent. The requirement for minimum free area is partly dependent on the design air permeability of the house. In older properties the air permeability will be above $5.0 \text{ m}^3/(\text{h} \cdot \text{m}^2)$, but in some modern properties it may be less. The vent must be positioned such that it is not liable to blockage.

Minimum areas are given in the following table:

Air Permeability $\text{m}^3/(\text{h} \cdot \text{m}^2)$	Minimum Vent Area $\text{cm}^2(\text{in}^2)$
> 5.0	No Requirement
<5.0	27.5 (4.3)

A fixed ducted air supply may be used as an alternative to the traditional method of using a permanent open vent into a room to supply air for combustion.

External air supply kits are available please contact Charnwood for more information.

This stove is capable of intermittent operation, and is not suitable for

use in a shared flue system.

In addition to these instructions the requirements of BS.8303 and BSEN 15287-1:2007 must be fulfilled. Local Authority Bylaws and Building Regulations, including those referring to national and European Standards, regarding the installation of Solid Fuel burning appliances, flues and chimneys must also be observed.

CO ALARMS

Building regulations require that whenever a new or replacement fixed solid fuel or wood/biomass appliance is installed in a dwelling a carbon monoxide alarm must be fitted in the same room as the appliance. Further guidance on the installation of the carbon monoxide alarm is available in BS EN 50292:2002 and from the alarm manufacturer's instructions. Provision of an alarm must not be considered a substitute for either installing the appliance correctly or ensuring regular servicing and maintenance of the appliance and chimney system.

SPECIFICATION

The outputs in the table are based on a 45 minute re-fuelling cycle burning seasoned hardwood logs. All tests are carried out in accordance with BSEN 13240.

Specification	
Nominal Heat Output kW (BTU/hr)	5.0 (17,000)
Stove Weight kg (Packed)	96
Flue Temperature °C	247
Minimum Flue Draught	12Pa
Flue gas Mass Flow g/s	4.2
Hearth Temperature °C	69.9
Minimum distance from combustibles mm	500 side 400 rear

CHIMNEY

In order for the appliance to perform satisfactorily the chimney height must not be less than 4 metres measured vertically from the outlet of the stove to the top of the chimney. The internal dimensions of the chimney should preferably be 150-200 mm (6" - 8") either square or round and MUST NOT BE LESS THAN 125 mm (5").

If an existing chimney is to be used it must be swept and checked, it must be in good condition, free from cracks and blockages, and

INSTALLATION INSTRUCTIONS



should not have an excessive cross sectional area. If it was previously used by an open fire then the chimney should be swept one month after installation to clear any soot falls which may have occurred due to the difference in combustion between the stove and the open fire. If you find that the chimney is in poor condition then expert advice should be sought regarding the necessity of having the chimney lined. If it is found necessary to line the chimney then a lining suitable for Solid Fuel must be used.

If there is no existing chimney then a prefabricated block chimney or a twin walled insulated stainless steel flue to BSEN 15287-1:2007 can be used either internally or externally. These chimneys must be fitted in accordance with the manufacturers instructions and Building Regulations.

Single wall flue pipe is suitable for connecting the stove to the chimney but is not suitable for using for the complete chimney. If it is found that there is excessive draw in the chimney then a draught stabiliser should be fitted.

It is important that there is sufficient draw in the chimney and that the chimney does not suffer from down-draught. When the chimney is warm the draw should be not less than 1.25mm (0.05") water gauge (12 Pa). If in doubt about the chimney seek expert advice.

HEARTH AND FIRE SURROUND

The stove must stand on a fireproof hearth and must not be situated closer than the minimum distance from combustible materials (see specification table) to the sides or rear above hearth level unless adequately fireproofed in accordance with local building regulations. The hearth must be of fireproof material and at least 12mm (1/2in.) thick. The positioning of the stove and the size of the hearth are governed by building regulations for Class 1 appliances. These building regulations state that the hearth must extend in front of the stove by at least 225mm (9 in.) and to the sides of the stove by at least 150mm (6 in.). When the fire door is open, it extends beyond the flat front of the stove by 436mm.

If in doubt as to the positioning of the stove, expert advice should be sought either from the supplier or the local building inspector. The fireplace must allow good circulation of air around the appliance to ensure that maximum heat is transferred to the room and also to prevent the fireplace from overheating. A gap of 150mm (6") each side and 300mm (12") above the appliance should give sufficient air circulation. If a wooden mantelpiece or beam is used in the fireplace it should be a minimum of 460mm (18"), and preferably 600mm (24") from the appliance. In some situations it may be necessary to shield

the beam or mantelpiece to protect it.

In order for the fire to operate correctly and to allow for access, there must be an air gap behind the appliance of at least 75mm, but be aware that this distance will need to be greater in some cases to meet Building Regulation requirements.

The appliance should be installed on a floor with adequate load-bearing capacity. If an existing construction does not meet this requirement then please take suitable measures to achieve this. (e.g. load distributing plate.)

Fig. 6. Vertical Register Plate With Bricked Up Fireplace

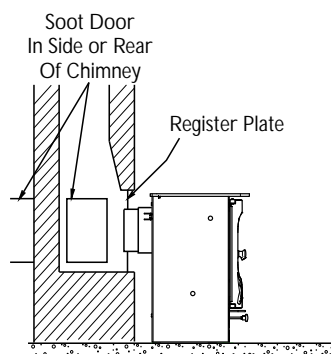

Fig. 7. Horizontal Register Plate With Rear Flue Connection

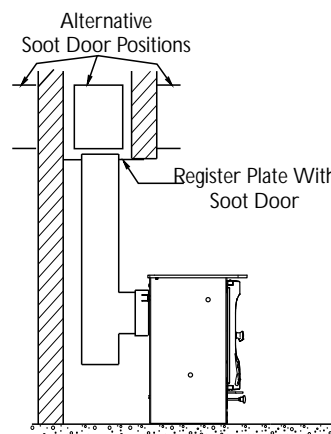

Fig. 8 Horizontal Register Plate With Top Flue Connection

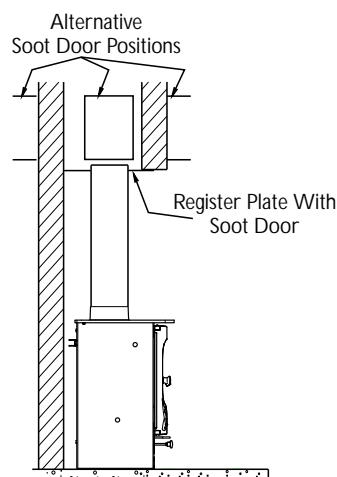
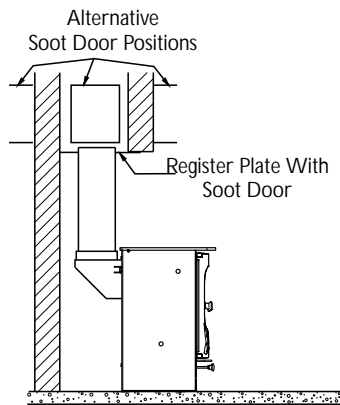



Fig. 9. Horizontal Register Plate With Optional Vertical Rear Flue Connector



CONNECTIONS TO FLUES

The stove must be connected to the flue using flue pipe of 125mm (5") diameter.

This may be stainless steel, cast iron, or thick wall steel pipe. Straight lengths of Charnwood Pipe to match the stove are available if required.

There are several ways of connecting the stove to the flue. These are illustrated in Figs. 6 to 9.

If the top flue connection or optional vertical rear flue connector is used then the chimney may be swept through the appliance.

Horizontal lengths of flue must be kept to a minimum and should not be more in length than the flue diameter.

The stove comes with the blanking plate (fig. 11) fitted to the top flue outlet. The seal for the top outlet is a 155mm dia ring of rope seal. The seal for the rear outlet is a length of adhesive backed fibre webbing supplied with instructions. This is applied to the flue collar or the Vertical Rear Flue adapter for rear outlet installations. For top outlet installations, the blanking plate must be removed, have the webbing fitted to its sealing face, and fitted to the rear flue outlet. Ensure that the fold on the clamping plate is in line with the lugs on the firebox as shown in Fig 8. Ensure that the clamping plate does not prevent the throat plate from seating correctly. All flue connections must be well sealed.

SOOT DOORS

It is possible to pass a 16 inch diameter sweeps brush through the appliance but in most back outlet installations it will be necessary to have a soot door to enable the chimney to be swept. The optional

vertical rear flue connector does allow the chimney to be swept through the stove. Soot doors may either be in the actual brickwork of the chimney or in the register plate. Various positions of soot doors are shown in Figs. 6 to 9.

PRE LIGHTING CHECK

Ensure that the throat plate is fitted in the roof of the appliance. The location and positioning of the throat plate is shown in Fig. 5.

Check that the front fence is fitted correctly and that the door closes properly.

COMMISSIONING

On completion of the installation allow a suitable period of time for the fire cement and mortar to dry out before lighting the fire. Make a layer of ash or sand on the base of the stove before lighting. Check to ensure that smoke and fumes are taken from the appliance up the chimney and emitted safely. Also check all joints and seals. On completion of the installation and commissioning please leave the operating instructions with the customer and advise them on the use of the appliance.

If an optional wood ash removal kit has been fitted, the wood ash retainer will need to be removed and left with the customer. Remind the customer that if the wood ash removal kit is removed; the wood ash retainer will need to be re-positioned before use. See figure 10.

Fig. 10 Wood Ash Deflector Position

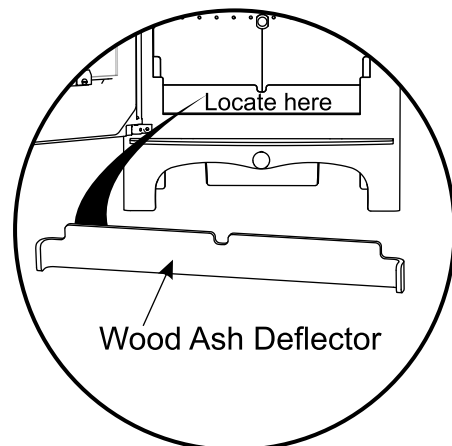

CAA AND SMOKE CONTROL

The Clean Air Act 1993 and Smoke Control Areas

Under the Clean Air Act local authorities may declare the whole or part of the district of the authority to be a smoke control area. It is an

INSTALLATION INSTRUCTIONS



offence to emit smoke from a chimney of a building, from a furnace or from any fixed boiler if located in a designated smoke control area. It is also an offence to acquire an "unauthorised fuel" for use within a smoke control area unless it is used in an "exempt" appliance ("exempted" from the controls which generally apply in the smoke control area).

The Secretary of State for Environment, Food and Rural Affairs has powers under the Act to authorise smokeless fuels or exempt appliances for use in smoke control areas in England. In Scotland and Wales this power rests with Ministers in the devolved administrations for those countries. Separate legislation, the Clean Air (Northern Ireland) Order 1981, applies in Northern Ireland. Therefore it is a requirement that fuels burnt or obtained for use in smoke control areas have been "authorised" in Regulations and that appliances used to burn solid fuel in those areas (other than "authorised" fuels) have been exempted by an Order made and signed by the Secretary of State or Minister in the devolved administrations.

The Charnwood Bembridge has been recommended as suitable for use in smoke control areas when burning wood logs.

Further information on the requirements of the Clean Air Act can be found here : <http://smokecontrol.defra.gov.uk/>

Your local authority is responsible for implementing the Clean Air Act 1993 including designation and supervision of smoke control areas and you can contact them for details of Clean Air Act requirements.

Fig. 11. Flue Blanking Plate.

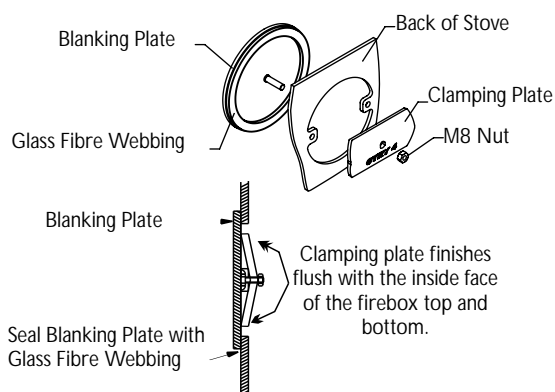



A.J WELLS & SONS LTD

15

Bishops Way, Newport, Isle of Wight PO30 5WS, United Kingdom

A Division of A.J.Wells & Sons Limited Registered in England No. 03809371

CE Certificate for compliance with EN13240:2001

EN13240:2001 ROOMHEATERS FIRED BY SOLID FUEL

BEMBRIDGE	
EC Certificate of conformity no:	AT044-CPD-2015
Fuel type:	WOOD LOGS
Emission of CO in combustion products:	0.06%
Mean flue gas temperature:	247°C
Space heating thermal output:	5.0kW
Energy efficiency	82%
Minimum distance to combustible materials Side: Rear:	500mm 400mm
With heat shield and HT+ insulated flue connector (25mm insulation). Side: Rear:	500mm 175mm
Particles (mg/m ³)	30
Fulfilled requirements: BStV of the City of Munich and the City of Regensburg FBStVO of the City of Aachen and the City of Düsseldorf 1.and 2. level of 1. BlmSchV of Germany	✓

CHARNWOOD BEMBRIDGE DIMENSIONS (mm)

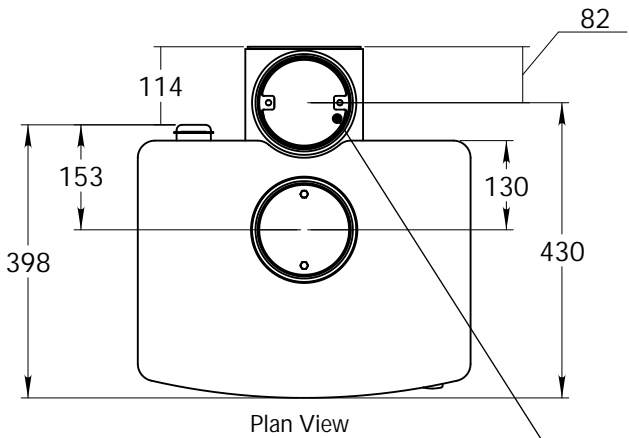

Optional Vertical Rear Flue Adapter

140 i/d to suit 125mm (5") flue pipe

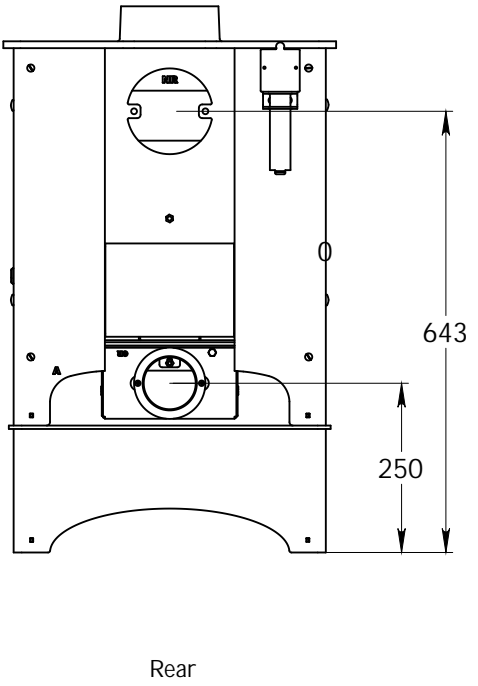
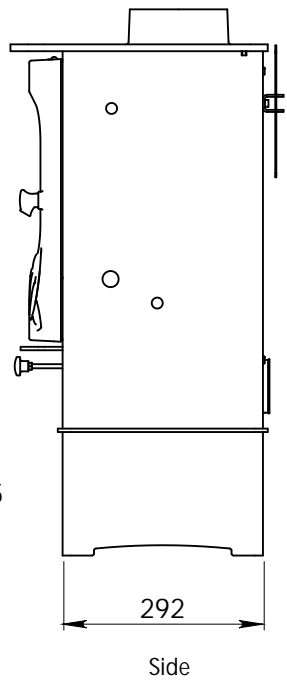
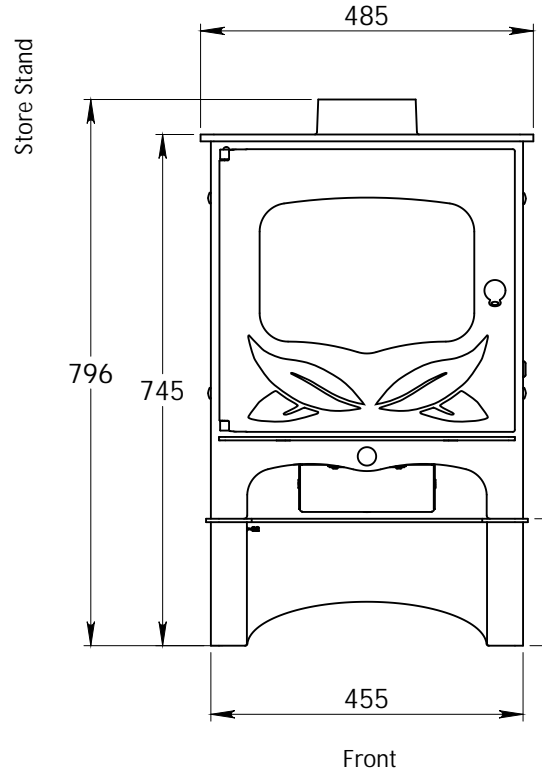
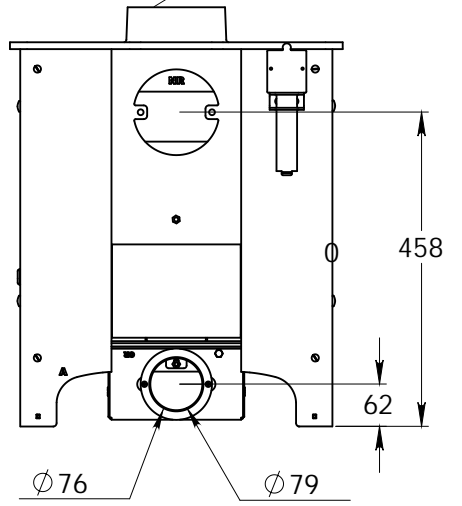
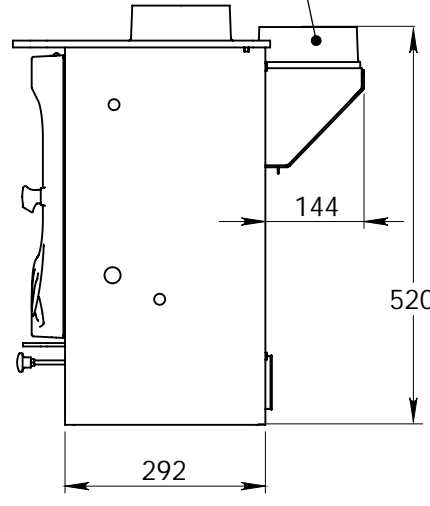
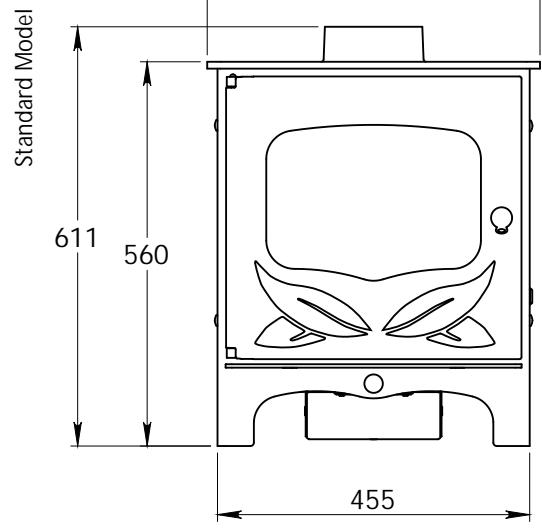

CHARNWOOD BEMBRIDGE PARTS LIST

Issue A

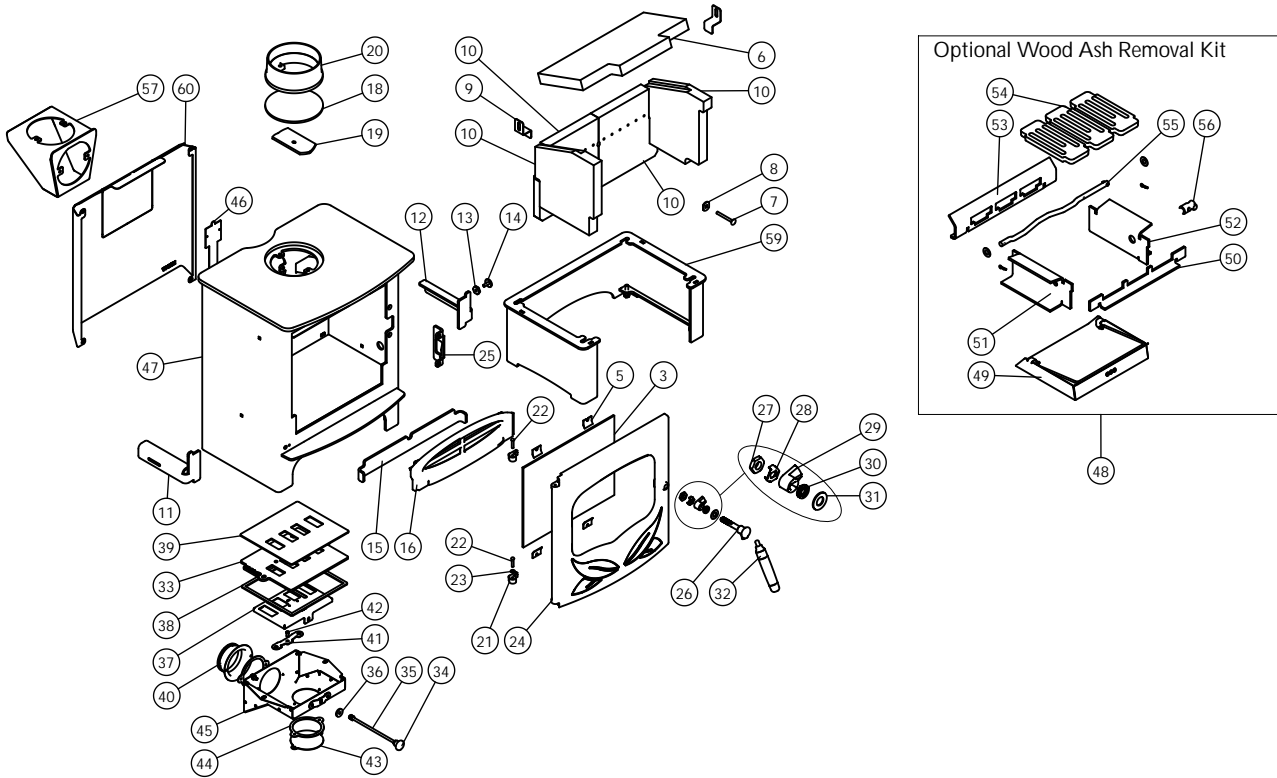

Item	Part No.	Description	Item	Part No.	Description
1*	008/AT002	Rope Door Seal 10mm	32	008/AT95	Door Tool
2*	008/FW29	Door Seal Adhesive	33	010/CR005	Air Control Plate
3	006/NR019	Glass	34	008/AY37	Air Control Knob
4*	008/NR044	Glass Seal	35	004/ER016	Control Rod
5	004/KV23	Glass Retainer	36	008/BR052	Felt Washer
6	010/NRE131	Brick Throat Plate	37	004/NRE007	Air Inlet Slide
7	008/FFB004	Coach Bolt M6 x 30	38	008/BR045	Lower Airbox Gasket
8	010/ERO36	Brick Retaining Washer	39	008/CR006	Airbox Gasket
9	004/XV30	Brick Bracket	40	008/CR048	Air Inlet Spigot
10	011/AT130/S	Set of Firebricks	41	004/BR015	Clicker Retainer Plate
11	010/NR028	L.H. Brick and Fence Support	42	008/ES36/01	Brass Ball Catch
12	010/NR029	R.H. Brick and Fence Support	43	004/CR064	Coverplate
13	010/AT023	Blanking Spacer	44	008/CR063	Duct Gasket
14	004/DY22	Riddler Hole Plug	45	004/CR041	Air Box Cover
15	010/AT078	Wood Ash Retainer	46	012/AT011	Serial No. Label
16	002/NR017	Fuel Retainer	47#	001/AT010	Firebox
17*	008/NV38	Flue Fixing Rope Seal	48	010/AT022	Grate Kit (Inc Handle)
18	012/PV09	Blanking Plate	49	004/AT011	Ashpan
19	010/AY51	Clamping Plate	50	010/EY06	Front Grate Support
20	002/PV12B	Flue Collar	51	010/NR043	L.H. Grate Support
21	002/BR020	Hinge Casting	52	010/NR042	R.H. Grate Support
22	008/BW39/S	Hinge Pin Set 5mm x 25mm	53	010/NR061	Rear Grate Support
23	008/FFW026	M6 Heay Brass Washer	54	002/EY03	Grate Plate
24#	002/AT001/A	Door Assembly	55	010/DR060	Riddler Rod
25	010/AT016	Latch Bracket	56	002/PX89	Riddler Knob
26	002/PX92	Door Knob & Spindle	57#	010/PV33	Vertical Rear Flue Adaptor (Opt'l Extra)
27	008/FFN001	M12 Half Nut	58*	010/EW51	Ash Carrier (Optional Extra)
28	004/ST008	Tabbed Locking Washer	59#	010/NR050	Store Stand (Optional Extra)
29	002/AY14	Door Catch	60#	010/NR057	Heat Shield (Optional Extra)
30	008/FFW015	M12 Double Coil Spring Washer	61*	004/AT097	Tool Pouch Hook
31	008/FFW008	M12 Washer	62*	008/AT096	Tool Holder Pouch

* These items are not shown on the drawing
Please specify colour when ordering.

To obtain spare parts please contact your local stockist giving Model, Part No. and Description. In case of difficulty contact the manufacturer at the address shown.
This drawing is for identification purposes only.

charnwood BISHOPS WAY, NEWPORT, ISLE OF WIGHT PO30 5WS, UNITED KINGDOM

T: +44 (0)1983 537799 • F: +44 (0)1983 537788 • WWW.CHARNWOOD.COM



your premier dealer

charnwood BISHOPS WAY, NEWPORT, ISLE OF WIGHT PO30 5WS, UNITED KINGDOM
T:+44 (0)1983 537777 • F:+44 (0)1983 537788 • CONTACT US AT WWW.CHARNWOOD.COM

